

Series 3800

Pilot Operated Pressure Relief Valves



The innovative, integrally cast, flanged semi-nozzle valves of Series 3800 are provided as self-contained units actuated by the snap-acting, non-flowing PCF3 (standard), HPCF3 (high pressure), and PCL (liquid service) pilot valves. All valves in the series are certified under Section VIII of the ASME Code for Air, Gas, Vapor and Liquid Service.

Available in API Orifices D through T as well as full bore models, Series 3800 valves are provided with raised face or ring joint inlet flanges from 150# through 2500# ANSI classes with 150# and 300# outlets. Set pressures range from 15 to 6170 psig with temperatures of -450°F to 450°F for standard options. Contact Factory about higher temperature and pressure requirements.

All Series 3800 valves are actuated by our PCF3, HPCF3 or PCL pilot controls with 316 stainless steel primary components as standard. The main valve body is carbon steel with 316 stainless steel trim. The main valve is also available in a full 316 stainless steel "S4" option, a NACE standard MR0175 "S7" option, and a cryogenic service valve.

Viton® soft goods are standard in both pilot control and main valves. Buna N, Neoprene, ethylene propylene, silicone and Teflon® soft goods are available as options; contact Factory for more information.

Table of Contents

Introduction	2
Principles of Operation.....	3
Main Valve Advantages/Bill of Materials.....	4-5
Pilot Control Valve Advantages/Bill of Materials.....	6-7
Selection Table for API Nozzle Design.....	8-9
Selection Tables for Full Port and Dual Outlet Designs.....	10
Air Capacity Tables.....	11-12
Natural Gas Capacity Tables	13-14
Water Capacity Table.....	15
Numbering System	16-17
Sizing Information.....	18
Back Pressure Sizing Factor Kb	18
Accessories.....	19
Dimensions and Weights for API Nozzle Design	20-21
Dimensions and Weights for Full Port Design.....	22
Other Farris Engineering Valves	23

Viton is a registered trademark of DuPont Dow Elastomers

Teflon is a registered trademark of the DuPont Company

Closed Valve Position: as the system approaches set pressure, the pressure pick-up transmits the pressure from the inlet of the main valve through the pilot control and into the dome of the main valve. This pressure acts upon the top of the piston in the dome, holding the piston firmly against the seat on the nozzle in the main valve. The surface area of the piston in the dome of the main valve is greater than the seat area, so the greater the system pressure, the greater the force holding the piston on the main valve seat. As a result, the pilot operated relief valve gets tighter as the system pressure approaches set pressure.

Relieving Cycle: at the point that the inlet pressure, acting on the surface area of the pilot control disc, overcomes the spring force in the pilot valve, the pilot valve lifts. The PCF3 is a non-flowing pilot control valve. As the seat assembly in the pilot control begins to lift, it seals off the flow of pressure to both the vent and the main valve dome. At the same time, the pressure in the dome is released through the pilot vent. Since the pressure in the dome has been released, the system pressure acting on the bottom of the piston will lift the piston and will relieve system overpressure.

Re-Closing Cycle: at the point where the system pressure blows down, the spring force in the pilot valve overcomes the force of system pressure acting on the pilot control seat assembly. The pilot control redirects system pressure back into the main valve dome, closing the main valve. Blowdown can be precisely adjusted externally by raising and lowering the blowdown adjuster position in the pilot valve.

Operating Advantages

Bubble-tight closer to set pressure: Series 3800 valves operate bubble tight at higher operating pressure to set pressure ratios, allowing operators to run very close to the system's maximum allowable working pressure. While protecting the system from overpressure, Series 3800 allows maximum product throughput, increased system profitability, and reduced fugitive emissions.

Unaffected by back pressure: unlike a direct spring loaded valve, the pilot operated valve's set pressure is not affected by back pressure. The pilot control valve, isolated from the influence of downstream pressure, controls the main valve's opening and closing.

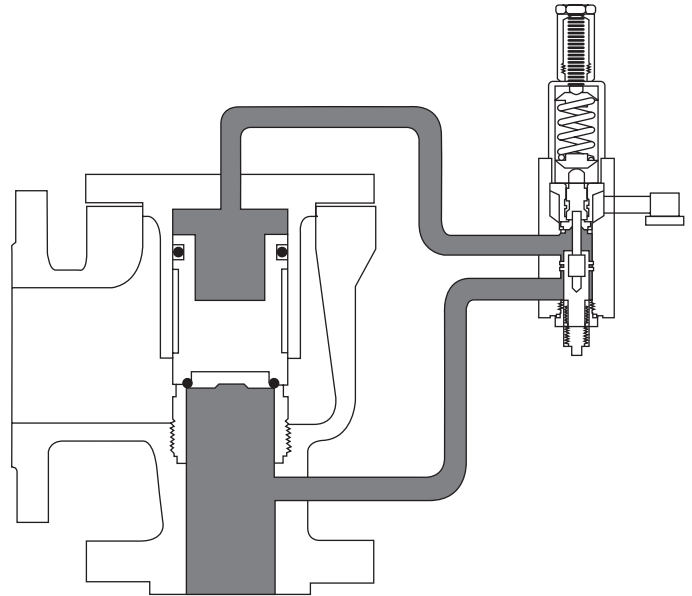

Closed Position

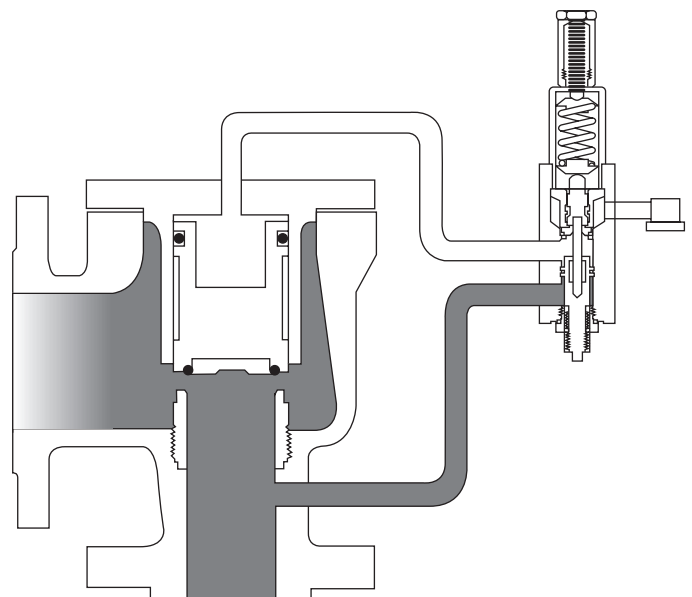

Relieving Position

Main Valve: Advantage Farris



Convertible Design: the unique convertible design minimizes the number of components and maximizes their interchangeability, reducing parts inventories and overall costs.

Convertible Nozzle: threaded convertible nozzles can be removed and replaced easily without factory service. They can be installed with common tools while the valve is in line, saving time and money.

Fewer Internal Components: the valve design requires no lift stops and the main valve opens fully at set pressure. The orifice area is controlled by the nozzle, eliminating the need for additional parts to restrict lift.

One Piece Body: integrally cast flanges assure the highest material integrity and eliminate problems that may occur with welding.

Full 316 Stainless Steel Trim: this trim is standard and includes nozzle, piston, retainer and guide for long and versatile service life.

Main Valve Soft Seat: unlike metal seated valves which require costly machining and lapping procedures, the main valve soft seat is easily maintained and repaired.

Less Weight, Lower Profile: system pressure provides the seating force in pilot operated relief valves so pilot valves are smaller in size and weight than direct spring loaded valves.

Convertible to NACE Service: with the high quality of construction materials, conversion for NACE Service to MR0175 is simple.

Convertible to Cryogenic Service: easy conversion for low temperature applications.

Full Bore Option: the full bore option provides maximum capacity per inlet size.

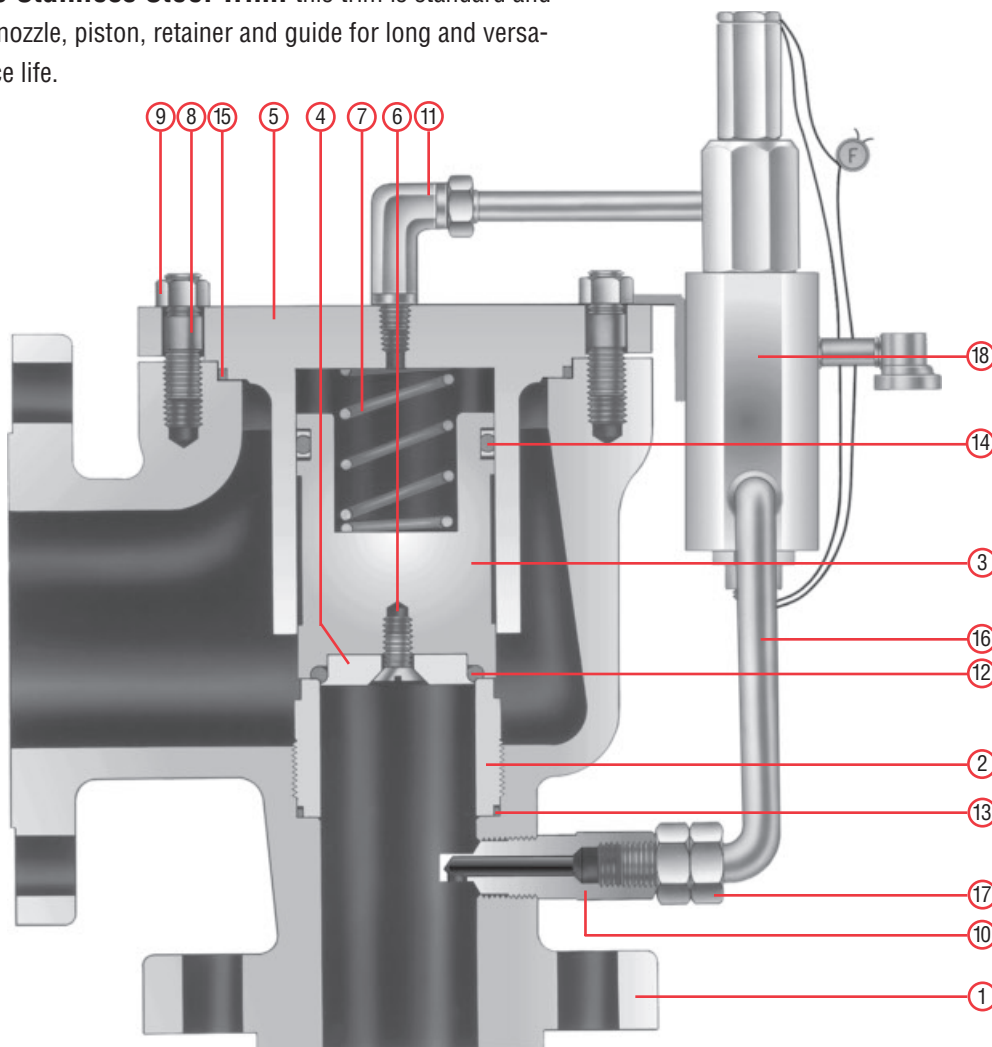

Built in conformance to ASME Code Section VIII for Air, Gas, Vapor, and Liquid Service.*

* ASME Code stamping not available on full port design in liquid service.



Series 3800 Main Valve Bill of Materials

Item No.	Part Name	Standard Material	S7 NACE MR0175	S4 Complete 316 St. St.
1	Body	SA-216 Gr. WCB Carbon Steel	SA-216 Gr. WCB Carbon Steel (Note 2)	SA-351 Gr. CF8M St. St. (316 St. St.)
2	Nozzle	316 St. St.	316 St. St.	316 St. St.
3	Piston	316 St. St.	316 St. St.	316 St. St.
4	Seat Retainer	316 St. St.	316 St. St.	316 St. St.
5	Guide / Cover	316 St. St.	316 St. St.	316 St. St.
Not Shown	Guide (Note 1)	316 St. St.	316 St. St.	316 St. St.
Not Shown	Cover (Note 1)	SA-216 Gr. WCB Carbon Steel	SA-216 Gr. WCB Carbon Steel (Note 2)	SA-351 Gr. CF8M St. St.
Not Shown	Cover Seal (Note 1)	Viton	Ethylene Propylene	Viton (Note 3)
6	Retainer Screw	316 St. St.	316 St. St.	316 St. St.
7	Preload Spring	316 St. St.	Inconel® X750	316 St. St.
8	Body Stud	ASTM A193 Gr. B7 Alloy Steel	ASTM A193 Gr. B7M Alloy Steel	ASTM A193 Gr. B8M St. St.
9	Hex Nut (Body)	ASTM A194 Gr. 2H Alloy Steel	ASTM A194 Gr. 2HM Alloy Steel	ASTM A194 Gr. 8M St. St.
10	Pressure Pickup	316 St. St.	316 St. St.	316 St. St.
11	Male Elbow (2)	316 St. St.	316 St. St.	316 St. St.
12	Seat Seal	Viton	Ethylene Propylene	Viton (Note 3)
13	Nozzle Seal	Viton	Ethylene Propylene	Viton (Note 3)
14	Piston Seal	Viton	Ethylene Propylene	Viton (Note 3)
15	Guide Seal	Viton	Ethylene Propylene	Viton (Note 3)
16	Tubing	316 St. St.	316 St. St.	316 St. St.
17	Male Connector	316 St. St.	316 St. St.	316 St. St.
18	Pilot Control	316 St. St.	316 St. St. (Inconel X750 Spring)	316 St. St.

General Notes:

1. Part used on 3" inlet sizes and larger.
2. Materials certified in compliance with NACE hardness requirements.
3. Teflon for seals required in main valve for temperatures below -20°F. Consult the Factory.
4. Teflon used for O-Ring Seat Seal (Item 12) for all valves with 900#, 1500#, and 2500# inlet flanges.

Inconel is a registered trademark of Inco Alloys International, Inc.

PCF3, HPCF3 & PCL Pilot Control Valves: Advantage Farris



Snap-Acting, Non-Flowing: the PCF3, HPCF3 and PCL pilot control valves are snap acting and non-flowing, minimizing the flow of line media through the pilot for reduced fugitive emissions and extended valve life.

Full 316 Stainless Steel Construction: resists corrosion and extends the life and versatility of the PCF3, HPCF3 and PCL valves.

Adjustable Blowdown: allows setting blowdown between 3% and 7% of set pressure so that product loss is minimized and fugitive emissions reduced.

Viton Seats and Seals: these corrosion-resistant seals and seats enhance valve life. Neoprene, ethylene propylene, silicone, and Buna N soft goods are optional and extend temperature ranges from -65°F to 450°F. Kalrez® available when maximum resistance to chemical attack is required. Contact factory for more information.

Set Pressures and Blowdown Set at Pilot Control Valve: in line service, settings and blowdown adjustments are completed quickly and easily without main valve intrusion. Subsequent reduction in product loss and fugitive emissions add to system profitability.

Field Test Capable: the use of a field test connection allows cycling the pilot valve without interrupting system protection or removing the valve from the line. Field testing verifies system integrity in accordance with the requirements of the Code.

Remote Sensing Capable: the pilot sensing line can be installed directly into the pressure vessel when the main valve is placed in the most ergonomic location. The relief valve, while remote from the vessel, operates on actual system pressure regardless of inlet piping losses.

Convertible to NACE Service: with the high quality of construction materials, conversion for NACE Service to MR0175 is simple.

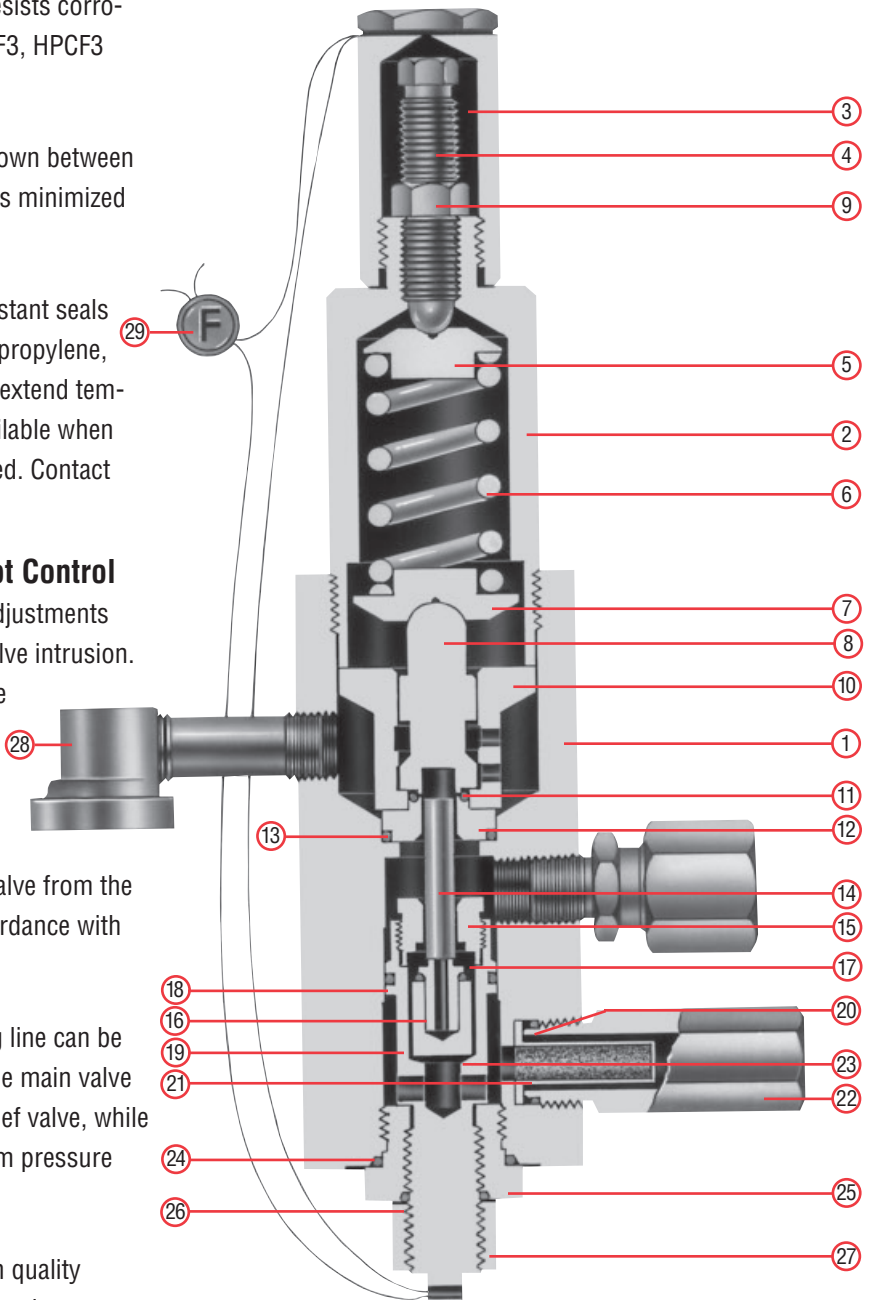

Built in conformance to ASME Code Section VIII for Air, Gas, Vapor, and Liquid Service.*

* ASME Code stamping not available on full port design in liquid service.

Kalrez is a registered trademark of DuPont Dow Elastomers



Series 3800 Pilot Control Valve Bill of Materials

Item No.	Part Name	Standard Material
1	Body	SA-479, 316 St. St.
2	Bonnet	SA-479, 316 St. St.
3	Cap	316 St. St.
4	Spring Adjusting Screw	316 St. St.
5	Upper Spring Button	316 St. St.
6	Spring - Standard	316 St. St.
	Spring - NACE	Inconel X750
7	Lower Spring Button	316 St. St.
8	Disc	316 St. St.
9	Jam Nut	18-8 St.
10	Guide	316 St. St.
11	Upper Seat Seal	Viton (Note 1)
12	Upper Seat	316 St. St.
13	Static Seal, Body	Viton (Note 1)
14	Blowdown Relay	316 St. St.
15	Lower Seat	316 St. St.
16	Retainer, Lower Seat Seal	316 St. St.
17	Lower Seat Seal	Viton (Note 1)
18	Static Seal, Adjuster	Viton (Note 1)
19	Blowdown Adjuster	A479, 316 St. St.
20	Static Seal, Filter	Viton (Note 1)
21	Filter	300 Series St. St.
22	Filter Housing	316 St. St.
23	Poppet	316 St. St.
24	Adjuster Cap Seal	Viton (Note 1)
25	Blowdown Adjuster Cap	316 St. St.
26	Thread Seal	Teflon
27	Blowdown Adjuster Lock Nut	18-8 St. St.
28	Bug Vent Housing	Commercial Grade
29	Wire Seal	St. St. Wire/Lead Seal
30	Nameplate (Not Shown)	Stainless Steel

General Notes:

1. For NACE Service (S7 Trim), substitute ethylene propylene.

Selection Table: API Nozzle Design



Orifice			Valve Size Inlet x Outlet	ANSI Flange Class		Type Number	Maximum Set Pressure, psig		Maximum Back Pressure psig at 100° F	
Letter	API Area Sq. In.	Actual Area Sq. In.		Inlet RF or RJ	Outlet RF		-20° F 100° F	500° F (Note 1)		
D	0.110	0.150	1 x 2	150#	150#	38DC10-120	285	170	285	
				300#		38DC12-120	740	600		
			600#	38DC13-120	1480	1200	740			
			900#	300#	38DC14-120	2220		1795		
1500#	38DC15-120	3705	2995							
2500#	38DC16-120	6170	4990	285						
1 1/2 x 2	150#	150#	38DC10X-120		285	170	285			
	300#		38DC12X-120		740	600				
	600#	38DC13X-120	1480		1200	740				
	900#	300#	38DC14X-120	2220	1795					
1500#	38DC15X-120		3705	2995						
2500#	38DC16X-120	6170	4990	285						
E	0.196	0.225	1 x 2		150#	150#	38EC10-120	285	170	285
					300#		38EC12-120	740	600	
			600#		38EC13-120	1480	1200	740		
			900#	300#	38EC14-120	2220	1795			
1500#	38EC15-120	3705	2995							
2500#	38EC16-120	6170	4990	285						
1 1/2 x 2	150#	150#	38EC10X-120		285	170	285			
	300#		38EC12X-120		740	600				
	600#	38EC13X-120	1480		1200	740				
	900#	300#	38EC14X-120	2220	1795					
1500#	38EC15X-120		3705	2995						
2500#	38EC16X-120	6170	4990	285						
F	0.307	0.371	1 x 2		150#	150#	38FC10-120	285	170	285
					300#		38FC12-120	740	600	
			600#		38FC13-120	1480	1200	740		
			900#	300#	38FC14-120	2220	1795			
1500#	38FC15-120	3705	2995							
2500#	38FC16-120	6170	4990	285						
1 1/2 x 2	150#	150#	38FC10X-120		285	170	285			
	300#		38FC12X-120		740	600				
	600#	38FC13X-120	1480		1200	740				
	900#	300#	38FC14X-120	2220	1795					
1500#	38FC15X-120		3705	2995						
2500#	38FC16X-120	6170	4990	285						
G	0.503	0.559	1 1/2 x 3		150#	150#	38GC10-120	285	170	285
					300#		38GC12-120	740	600	
			600#		38GC13-120	1480	1200	740		
			900#	300#	38GC14-120	2220	1795			
1500#	38GC15-120	3705	2995							
2500#	38GC16-120	6170	4990	285						
2 x 3	150#	150#	38GC10X-120		285	170	285			
	300#		38GC12X-120		740	600				
	600#	38GC13X-120	1480		1200	1480				
	900#	300#/600# (Note 2)	38GC14X-120	2220	1795					
1500#	38GC15X-120		3705	2995						
2500#	38GC16X-120	6170	4990	286						
H	0.785	0.873	1 1/2 x 3		150#	150#	38HC10-120	285	170	286
					300#		38HC12-120	740	600	
			600#		38HC13-120	1480	1200	740		
			900#	300#	38HC14-120	2220	1795			
1500#	38HC15-120	3705	2995							
2500#	38HC16-120	6170	4990	285						
2 x 3	150#	150#	38HC10X-120		285	170	285			
	300#		38HC12X-120		740	600				
	600#	38HC13X-120	1480		1200	1480				
	900#	300#/600# (Note 2)	38HC14X-120	2220	1795					
1500#	38HC15X-120		3705	2995						
2500#	38HC16X-120	6170	4990							



Selection Table: API Nozzle Design

Orifice			Valve Size Inlet x Outlet	ANSI Flange Class		Type Number	Maximum Set Pressure, psig		Maximum Back Pressure psig at 100° F
Letter	API Area Sq. In.	Actual Area Sq. In.		Inlet RF or RJ	Outlet RF		-20° F 100° F	500° F (Note 1)	
J	1.287	1.430	2 x 3	150#	150#	38JC10-120	285	170	285
				300#		38JC12-120	740	600	
			600#		38JC13-120	1480	1200		
			900#	300#/600# (Note 2)	38JC14-120	2220	1795	1480	
1500#		38JC15-120	3705	2995					
2500#		38JC16-120	6170	4990					
3 x 4	150#	150#	38JC10X-120	285	170	285			
	300#		38JC12X-120	740	600				
600#		38JC13X-120	1480	1200					
900#	300#	38JC14X-120	2220	1795	740				
1500#		38JC15X-120	3705	2995					
K	1.838	2.042	3 x 4	150#	150#	38KC10-120	285	170	285
				300#		38KC12-120	740	600	
600#		38KC13-120	1480	1200					
900#	300#	38KC14-120	2220	1795	740				
1500#		38KC15-120	3705	2995					
L	2.853	3.170	3 x 4	150#	150#	38LC10-120	285	170	285
				300#		38LC12-120	740	600	
			600#		38LC13-120	1480	1200		
			900#	300#	38LC14-120	2220	1795	740	
1500#		38LC15-120	3705	2995					
4 x 6	150#	150#	38LC10X-120	285	170	285			
300#		38LC12X-120	740	600					
600#		38LC13X-120	1480	1200					
M	3.60	4.000	4 x 6	150#	150#	38MC10-120	285	170	285
300#		38MC12-120	740	600					
600#		38MC13-120	1480	1200					
N	4.34	4.822	4 x 6	150#	150#	38NC10-120	285	170	285
300#		38NC12-120	740	600					
600#		38NC13-120	1480	1200					
P	6.38	7.087	4 x 6	150#	150#	38PC10-120	285	170	285
300#		38PC12-120	740	600					
600#		38PC13-120	1480	1200					
Q	11.05	12.27	6 x 8	150#	150#	38QC10-120	285	170	285
300#		38QC12-120	740	600					
600#		38QC13-120	1480	1200					
R	16.0	17.78	6 x 8	150#	150#	38RC10-120	285	170	285
300#		38RC12-120	740	600					
600#		38RC13-120	1480	1200					
T	26.0	28.94	8 x 10	150#	150#	38TC10-120	285	170	285
300#		38TC12-120	740	600					
600#		38TC13-120	1480	1200					

General Notes:

- Standard elastomer is Viton which is suitable to a maximum temperature of 450°F. For temperatures above 450°F, the O-Ring Seals must be specified as Kalrez®. Consult the Factory.
- The 300# and 600# flanges have identical drilling with flange thickness equal to the 600# class.
- For liquid service applications, add "L" to the type number for valves with standard size connections and "Y" for valves with oversize connections. Example: 38FC10L-120 and 38FC10Y-120.
- Valves with ring joint inlet connections available on application only. Consult the Factory.

Selection Table: Full Port Design



Orifice		Valve Size Inlet x Outlet	ANSI Flange Class		Type Number	Maximum Set Pressure, psig		Maximum Back Pressure psig at 100° F
Letter	Actual Area Sq. In.		Inlet RF or RJ	Outlet RF		-20° F 100° F	500° F (Note 1)	
1	1.767	1 1/2 x 2	150#	150#	381C10-120	285	170	285
			300#		381C12-120	740	600	
		600#	381C13-120	1480	1200			
		900#	300#	381C14-120	2220	1795	740	
1500#	381C15-120	3705		2995				
2500#	381C16-120	6170	4990					
2	2.953	2 x 3	150#	150#	382C10-120	285	170	285
			300#		382C12-120	740	600	
		600#	382C13-120	1480	1200			
		900#	300#/600# (Note 2)	382C14-120	2220	1795	1480	
1500#	382C15-120	3705		2995				
2500#	382C16-120	6170	4990					
3	6.605	3 x 4	150#	150#	383C10-120	285	170	285
			300#		383C12-120	740	600	
		600#	383C13-120	1480	1200			
		900#	300#	383C14-120	2220	1795	740	
1500#	383C15-120	3705		2995				
4	11.50	4 x 6	150#	150#	384C10-120	285	170	285
			300#		384C12-120	740	600	
			600#		384C13-120	1480	1200	
			6		26.07	6 x 8	150#	
300#	386C12-120	740		600				
600#	386C13-120	1480		1200				
8	45.66	8 x 10		150#			150#	388C10-120
			300#	388C12-120	740	600		
			600#	388C13-120	1480	1200		

Selection Table: Dual Port Design

Orifice			Valve Size Inlet x Outlet	ANSI Flange Class		Type Number	Maximum Set Pressure, psig		Maximum Back Pressure psig at 100° F
Letter	API Area Sq. In.	Actual Area Sq. In.		Inlet RF or RJ	Outlet RF		-20° F 100° F	500° F (Note 1)	
Q	11.05	12.27	6 x 8 x 8	150#	150#	38QC10D-120	285	170	285
				300#		38QC12D-120	740	600	
				600#		38QC13D-120	1480	1200	
R	16.0	17.78	6 x 8 x 8	150#	300#	38RC10D-120	285	170	285
				300#		38RC12D-120	740	600	
				600#		38RC13D-120	1480	1200	
T	26.0	28.94	8 x 10 x 10	150#	150#	38TC10D-120	285	170	285
				300#		38TC12D-120	740	600	
				600#		38TC13D-120	1480	1200	
#6	-	26.07	6 x 8 x 8	150#	300#	386C10D-120	285	170	285
				300#		386C12D-120	740	600	
				600#		386C13D-120	1480	1200	
#8	-	45.66	8 x 10 x 10	150#	150#	388C10D-120	285	170	285
				300#		388C12D-120	740	600	
				600#		388C13D-120	1480	1200	

General Notes:

- Standard elastomer is Viton which is suitable to a maximum temperature of 450°F. For temperatures above 450°F, the O-Ring Seals must be specified as Kalrez. Consult the Factory.
- The 300# and 600# flanges have identical drilling with flange thickness equal to the 600# class.
- Full port design suitable for use on air, gas, and vapor services only.
- A 1" X 2" valve is available with an "A" orifice (0.719 sq. in.) provided remote sensing is specified.
- Valves with ring joint inlet connections available on application only. Consult the Factory.
- For dual outlet API Orifice types, liquid service valves are designated by changing the seventh digit from "D" to "E". The full bore design is not available for use on liquid service.



Air Capacities: API Nozzle, 10% Overpressure

ASME PRESSURE VESSEL CODE (UV) CAPACITIES IN STANDARD CUBIC FEET PER MINUTE AT 60°F

Set Pressure (psig)	Orifice Area, Sq. Inches													
	D	E	F	G	H	J	K	L	M	N	P	Q	R	T
	0.110	0.196	0.307	0.503	0.785	1.287	1.838	2.853	3.60	4.34	6.38	11.05	16.0	26.0
15	77	115	191	287	449	736	1051	1632	2059	2482	3649	6317	9155	14901
20	89	133	220	331	518	848	1212	1881	2374	2862	4207	7283	10554	17179
30	112	168	278	419	655	1074	1533	2380	3004	3621	5323	9215	13354	21736
40	138	207	342	516	806	1321	1887	2930	3697	4457	6550	11341	16434	26749
50	164	246	407	613	958	1569	2241	3479	4390	5292	7778	13466	19513	31762
60	190	285	471	710	1109	1817	2594	4028	5082	6127	9005	15591	22593	36774
70	216	324	535	807	1260	2064	2948	4577	5775	6962	10233	17717	25673	41787
80	242	363	599	903	1411	2312	3302	5126	6468	7797	11460	19842	28752	46800
90	268	402	664	1000	1562	2560	3655	5675	7161	8633	12688	21967	31832	51812
100	294	441	728	1097	1714	2807	4009	6224	7854	9468	13915	24092	34912	56825
150	424	636	1049	1581	2470	4046	5778	8969	11318	13644	20053	34719	50310	81889
200	554	831	1371	2065	3226	5284	7546	11715	14782	17820	26191	45345	65708	106952
250	684	1026	1692	2549	3982	6523	9315	14460	18246	21996	32328	55972	81107	132015
300	814	1221	2013	3034	4738	7761	11083	17205	21711	26172	38466	66598	96505	157079
350	944	1416	2335	3518	5494	9000	12851	19951	25175	30348	44604	77225	111903	182142
400	1073	1610	2656	4002	6250	10238	14620	22696	28639	34524	50741	87851	127302	207206
450	1203	1805	2977	4486	7006	11477	16388	25442	32103	38700	56879	98477	142700	232269
500	1333	2000	3298	4970	7762	12715	18157	28187	35567	42876	63017	109104	158098	257333
550	1463	2195	3620	5454	8518	13953	19925	30932	39032	47053	69154	119730	173497	282396
600	1593	2390	3941	5938	9274	15192	21694	33678	42496	51229	75292	130357	188895	307459
650	1723	2585	4262	6422	10030	16430	23462	36423	45960	55405	81430	140983	204293	332523
700	1853	2780	4584	6907	10786	17669	25231	39168	49424	59581	87567	151609	219692	357586
750	1983	2974	4905	7391	11542	18907	26999	41914	52888	63757	93705	162236	235090	382650
800	2113	3169	5226	7875	12299	20146	28768	44659	56352	67933	99843	172862	250488	407713
850	2243	3364	5548	8359	13055	21384	30536	47405	59817	72109	105981	183489	265887	432777
900	2373	3559	5869	8843	13811	22623	32305	50150	63281	76285	112118	194115	281285	457840
950	2502	3754	6190	9327	14567	23861	34073	52895	66745	80461	118256	204741	296683	482903
1000	2632	3949	6511	9811	15323	25099	35842	55641	70209	84637	124394	215368	312082	507967
1050	2762	4144	6833	10295	16079	26338	37610	58386	73673	88813	130531	225994	327480	533030
1100	2892	4339	7154	10780	16835	27576	39379	61131	77138	92989	136669	236621	342878	558094
1150	3022	4533	7475	11264	17591	28815	41147	63877	80602	97166	142807	247247	358277	583157
1200	3152	4728	7797	11748	18347	30053	42915	66622	84066	101342	148944	257873	373675	608221
1250	3282	4923	8118	12232	19103	31292	44684	69368	87530	105518	155082	268500	389073	633284
1300	3412	5118	8439	12716	19859	32530	46452	72113	90994	109694	161220	279126	404472	658348
1350	3542	5313	8761	13200	20615	33769	48221	74858	94459	113870	167357	289753	419870	683411
1400	3672	5508	9082	13684	21371	35007	49989	77604	97923	118046	173495	300379	435268	708474
1450	3802	5703	9403	14168	22127	36246	51758	80349	101387	122222	179633	311006	450667	733538
1500	3931	5897	9724	14653	22883	37484	53526	83094	—	—	—	—	—	—
1550	4061	6092	10046	15137	23639	38722	55295	85840	—	—	—	—	—	—
1600	4191	6287	10367	15621	24395	39961	57063	88585	—	—	—	—	—	—
1650	4321	6482	10688	16105	25152	41199	58832	91331	—	—	—	—	—	—
1700	4451	6677	11010	16589	25908	42438	60600	94076	—	—	—	—	—	—
1750	4581	6872	11331	17073	26664	43676	62369	96821	—	—	—	—	—	—
1800	4711	7067	11652	17557	27420	44915	64137	99567	—	—	—	—	—	—
1850	4841	7261	11974	18041	28176	46153	65906	102312	—	—	—	—	—	—
1900	4971	7456	12295	18525	28932	47392	67674	105057	—	—	—	—	—	—
2000	5231	7846	12938	19494	30444	49868	71211	110548	—	—	—	—	—	—
2100	5490	8236	13580	20462	31956	52345	74748	116039	—	—	—	—	—	—
2200	5750	8625	14223	21430	33468	54822	78285	121530	—	—	—	—	—	—
2300	6010	9015	14865	22398	34980	57299	81822	127020	—	—	—	—	—	—
2400	6270	9405	15508	23367	36492	59776	85359	132511	—	—	—	—	—	—
2500	6530	9795	16151	24335	38005	62253	88896	138002	—	—	—	—	—	—
2600	6789	10184	16793	25303	39517	64730	92433	143493	—	—	—	—	—	—
2700	7049	10574	17436	26271	41029	67207	95970	148983	—	—	—	—	—	—
2800	7309	10964	18078	27240	42541	69684	99506	154474	—	—	—	—	—	—
2900	7569	11354	18721	28208	44053	72161	103043	159965	—	—	—	—	—	—
3000	7829	11743	19364	29176	45565	74637	106580	165456	—	—	—	—	—	—
3500	9128	13692	22577	34017	53126	87022	124265	192909	—	—	—	—	—	—
4000	10427	15640	25790	38859	60686	99406	141950	220363	—	—	—	—	—	—
4500	11726	17589	29003	43700	68247	111791	—	—	—	—	—	—	—	—
5000	13025	19538	32216	48541	75808	124175	—	—	—	—	—	—	—	—
5500	14324	21486	35429	53382	83368	136560	—	—	—	—	—	—	—	—
6000	15623	23435	38642	58223	90929	148944	—	—	—	—	—	—	—	—
6170	16065	24097	39734	59869	93499	153155	—	—	—	—	—	—	—	—

General Notes:

1. Capacities at 30 psig and below are based on 3 psi overpressure.

Air Capacities: Full Port, 10% Overpressure

ASME PRESSURE VESSEL CODE (UV) CAPACITIES IN STANDARD CUBIC FEET PER MINUTE AT 60°F



Set Pressure (psig)	Orifice Area, Sq. Inches						
	A	#1	#2	#3	#4	#6	#8
	0.719	1.767	2.953	6.605	11.50	26.07	45.66
15	345	848	1417	3171	5521	12517	21923
20	398	978	1634	3656	6365	14431	25275
30	503	1237	2068	4626	8054	18259	31979
40	619	1522	2545	5692	9911	22469	39354
50	735	1808	3022	6759	11769	26680	46729
60	851	2093	3499	7826	13626	30891	54103
70	968	2379	3976	8893	15484	35101	61478
80	1084	2664	4452	9960	17341	39312	68853
90	1200	2949	4929	11026	19198	43523	76228
100	1316	3235	5406	12093	21056	47733	83602
150	1897	4662	7791	17427	30343	68787	120476
200	2477	6089	10176	22761	39630	89840	157350
250	3058	7516	12561	28095	48917	110894	194224
300	3639	8943	14945	33429	58204	131947	231097
350	4219	10370	17330	38763	67491	153000	267971
400	4800	11797	19715	44097	76778	174054	304845
450	5380	13224	22100	49431	86065	195107	341719
500	5961	14651	24484	54765	95352	216161	378592
550	6542	16078	26869	60099	104640	237214	415466
600	7122	17505	29254	65433	113927	258267	452340
650	7703	18932	31639	70767	123214	279321	489214
700	8284	20359	34024	76101	132501	300374	526087
750	8864	21786	36408	81435	141788	321428	562961
800	9445	23213	38793	86769	151075	342481	599835
850	10026	24640	41178	92103	160362	363534	636709
900	10606	26067	43563	97437	169649	384588	673582
950	11187	27494	45947	102771	178936	405641	710456
1000	11768	28920	48332	108105	188223	426695	747330
1050	12348	30347	50717	113439	197510	447748	784204
1100	12929	31774	53102	118773	206797	468801	821077
1150	13510	33201	55486	124107	216085	489855	857951
1200	14090	34628	57871	129441	225372	510908	894825
1250	14671	36055	60256	134775	234659	531962	931699
1300	15251	37482	62641	140110	243946	553015	968572
1350	15832	38909	65025	145444	253233	574069	1005446
1400	16413	40336	67410	150778	262520	595122	1042320
1450	16993	41763	69795	156112	271807	616175	1079194
1500	17574	43190	72180	161446	—	—	—
1550	18155	44617	74564	166780	—	—	—
1600	18735	46044	76949	172114	—	—	—
1650	19316	47471	79334	177448	—	—	—
1700	19897	48898	81719	182782	—	—	—
1750	20477	50325	84104	188116	—	—	—
1800	21058	51752	86488	193450	—	—	—
1850	21639	53179	88873	198784	—	—	—
1900	22219	54606	91258	204118	—	—	—
2000	23380	57460	96027	214786	—	—	—
2100	24542	60314	100797	225454	—	—	—
2200	25703	63168	105566	236122	—	—	—
2300	26864	66022	110336	246790	—	—	—
2400	28026	68876	115105	257458	—	—	—
2500	29187	71730	119875	268126	—	—	—
2600	30348	74584	124644	278794	—	—	—
2700	31509	77438	129414	289462	—	—	—
2800	32671	80292	134183	300130	—	—	—
2900	33832	83146	138953	310798	—	—	—
3000	34993	86000	143723	321466	—	—	—
3500	40800	100269	167570	374806	—	—	—
4000	46606	114539	191418	—	—	—	—
4500	52413	128809	215265	—	—	—	—
5000	58219	143079	239113	—	—	—	—
5500	64026	157349	262961	—	—	—	—
6000	69832	171619	286808	—	—	—	—
6170	71806	176470	294916	—	—	—	—

General Notes:

1. Capacities at 30 psig and below are based on 3 psi overpressure.



Natural Gas Capacities: API Nozzle

ASME PRESSURE VESSEL CODE (UV) CAPACITIES IN STANDARD CUBIC FEET PER MINUTE AT 60°F

Set Pressure (psig)	Orifice Area, Sq. Inches													
	D	E	F	G	H	J	K	L	M	N	P	Q	R	T
	0.110	0.196	0.307	0.503	0.785	1.287	1.838	2.853	3.60	4.34	6.38	11.05	16.0	26.0
15	93	139	230	347	542	888	1268	1969	2484	2995	4402	7622	11045	17978
20	107	161	265	400	625	1024	1462	2270	2864	3453	5075	8788	12734	20727
30	135	203	336	506	791	1295	1850	2872	3624	4369	6422	11119	16112	26225
40	167	250	413	623	973	1594	2277	3535	4460	5377	7903	13683	19827	32273
50	198	297	491	740	1155	1893	2703	4197	5296	6385	9384	16247	23543	38320
60	229	344	568	857	1338	2192	3130	4860	6132	7392	10865	18811	27259	44368
70	261	391	646	973	1520	2491	3557	5522	6968	8400	12346	21375	30974	50416
80	292	438	723	1090	1703	2790	3984	6184	7804	9408	13827	23939	34690	56464
90	324	486	801	1207	1885	3088	4410	6847	8640	10415	15308	26503	38405	62512
100	355	533	878	1324	2068	3387	4837	7509	9476	11423	16789	29068	42121	68559
150	512	768	1266	1908	2980	4881	6971	10822	13655	16461	24194	41888	60699	98798
200	668	1003	1654	2492	3892	6376	9104	14134	17835	21500	31599	54709	79277	129037
250	825	1238	2041	3076	4804	7870	11238	17446	22014	26538	39004	67530	97855	159276
300	982	1473	2429	3660	5716	9364	13372	20758	26194	31577	46409	80350	116433	189515
350	1139	1708	2817	4244	6629	10858	15505	24071	30373	36615	53814	93171	135011	219754
400	1295	1943	3204	4828	7541	12352	17639	27383	34553	41654	61219	105992	153589	249993
450	1452	2178	3592	5412	8453	13847	19773	30695	38732	46692	68625	118813	172167	280232
500	1609	2413	3980	5997	9365	15341	21906	34008	42912	51730	76030	131633	190745	310471
550	1765	2648	4367	6581	10277	16835	24040	37320	47091	56769	83435	144454	209323	340710
600	1922	2884	4755	7165	11190	18329	26174	40632	51271	61807	90840	157275	227901	370949
650	2079	3119	5143	7749	12102	19823	28307	43944	55451	66846	98245	170096	246479	401188
700	2236	3354	5530	8333	13014	21317	30441	47257	59630	71884	105650	182916	265057	431427
750	2392	3589	5918	8917	13926	22812	32575	50569	63810	76923	113055	195737	283635	461666
800	2549	3824	6306	9501	14838	24306	34708	53881	67989	81961	120460	208558	302213	491905
850	2706	4059	6693	10085	15750	25800	36842	57194	72169	86999	127865	221378	320791	522143
900	2863	4294	7081	10669	16663	27294	38976	60506	76348	92038	135270	234199	339370	552382
950	3019	4529	7468	11253	17575	28788	41109	63818	80528	97076	142675	247020	357948	582621
1000	3176	4764	7856	11837	18487	30283	43243	67130	84707	102115	150081	259841	376526	612860
1050	3333	4999	8244	12422	19399	31777	45376	70443	88887	107153	157486	272661	395104	643099
1100	3490	5235	8631	13006	20311	33271	47510	73755	93066	112192	164891	285482	413682	673338
1150	3646	5470	9019	13590	21224	34765	49644	77067	97246	117230	172296	298303	432260	703577
1200	3803	5705	9407	14174	22136	36259	51777	80380	101425	122268	179701	311124	450838	733816
1250	3960	5940	9794	14758	23048	37753	53911	83692	105605	127307	187106	323944	469416	764055
1300	4116	6175	10182	15342	23960	39248	56045	87004	109784	132345	194511	336765	487994	794294
1350	4273	6410	10570	15926	24872	40742	58178	90316	113964	137384	201916	349586	506572	824533
1400	4430	6645	10957	16510	25784	42236	60312	93629	118144	142422	209321	362406	525150	854772
1450	4587	6880	11345	17094	26697	43730	62446	96941	122323	147461	216726	375227	543728	885011
1500	4743	7115	11733	17678	27609	45224	64579	100253	—	—	—	—	—	—
1550	4900	7350	12120	18262	28521	46719	66713	103566	—	—	—	—	—	—
1600	5057	7585	12508	18846	29433	48213	68847	106878	—	—	—	—	—	—
1650	5214	7821	12896	19431	30345	49707	70980	110190	—	—	—	—	—	—
1700	5370	8056	13283	20015	31258	51201	73114	113502	—	—	—	—	—	—
1750	5527	8291	13671	20599	32170	52695	75248	116815	—	—	—	—	—	—
1800	5684	8526	14059	21183	33082	54189	77381	120127	—	—	—	—	—	—
1850	5840	8761	14446	21767	33994	55684	79515	123439	—	—	—	—	—	—
1900	5997	8996	14834	22351	34906	57178	81649	126751	—	—	—	—	—	—
2000	6311	9466	15609	23519	36731	60166	85916	133376	—	—	—	—	—	—
2100	6624	9936	16384	24687	38555	63155	90183	140001	—	—	—	—	—	—
2200	6938	10407	17160	25856	40379	66143	94450	146625	—	—	—	—	—	—
2300	7251	10877	17935	27024	42204	69131	98718	153250	—	—	—	—	—	—
2400	7565	11347	18710	28192	44028	72120	102985	159874	—	—	—	—	—	—
2500	7878	11817	19486	29360	45852	75108	107252	166499	—	—	—	—	—	—
2600	8191	12287	20261	30528	47677	78096	111520	173123	—	—	—	—	—	—
2700	8505	12758	21036	31696	49501	81085	115787	179748	—	—	—	—	—	—
2800	8818	13228	21812	32865	51326	84073	120054	186373	—	—	—	—	—	—
2900	9132	13698	22587	34033	53150	87062	124322	192997	—	—	—	—	—	—
3000	9445	14168	23362	35201	54974	90050	128589	199622	—	—	—	—	—	—
3500	11013	16519	27239	41042	64096	104992	149925	232745	—	—	—	—	—	—
4000	12580	18870	31115	46883	73218	119934	171262	265867	—	—	—	—	—	—
4500	14147	21221	34992	52724	82340	134875	—	—	—	—	—	—	—	—
5000	15715	23572	38868	58565	91462	149817	—	—	—	—	—	—	—	—
5500	17282	25923	42745	64406	100583	164759	—	—	—	—	—	—	—	—
6000	18849	28274	46621	70246	109705	179701	—	—	—	—	—	—	—	—
6170	19382	29074	47939	72232	112807	184781	—	—	—	—	—	—	—	—

General Notes:

1. Minimum set pressure for 1" x 2" size valves in any orifice is 20 psig.
2. Capacities based on a specific gravity of 0.65 at a temperature of 60°F.
3. Capacities at 30 psig and below are based on 3 psi overpressure.

Natural Gas Capacities: Full Port



ASME PRESSURE VESSEL CODE (UV) CAPACITIES IN STANDARD CUBIC FEET PER MINUTE AT 60°F

Set Pressure (psig)	Orifice Area, Sq. Inches						
	A	#1	#2	#3	#4	#6	#8
	0.719	1.767	2.953	6.605	11.50	26.07	45.66
15	416	1023	1710	3826	6661	15101	26450
20	480	1180	1972	4411	7680	17411	30494
30	607	1493	2495	5581	9717	22029	38583
40	747	1837	3070	6868	11958	27109	47480
50	887	2181	3646	8155	14199	32189	56378
60	1027	2526	4221	9442	16440	37269	65276
70	1168	2870	4797	10729	18681	42350	74173
80	1308	3214	5372	12016	20922	47430	83071
90	1448	3559	5947	13303	23163	52510	91968
100	1588	3903	6523	14590	25404	57590	100866
150	2288	5625	9400	21026	36609	82991	145354
200	2989	7346	12277	27461	47814	108392	189842
250	3689	9068	15155	33897	59018	133793	234330
300	4390	10790	18032	40332	70223	159194	278818
350	5091	12511	20909	46768	81428	184594	323306
400	5791	14233	23786	53203	92633	209995	367794
450	6492	15954	26663	59639	103838	235396	412282
500	7192	17676	29541	66074	115043	260797	456770
550	7893	19398	32418	72510	126247	286198	501258
600	8593	21119	35295	78945	137452	311599	545746
650	9294	22841	38172	85381	148657	337000	590234
700	9994	24563	41049	91816	159862	362400	634723
750	10695	26284	43927	98252	171067	387801	679211
800	11395	28006	46804	104687	182271	413202	723699
850	12096	29728	49681	111122	193476	438603	768187
900	12797	31449	52558	117558	204681	464004	812675
950	13497	33171	55435	123993	215886	489405	857163
1000	14198	34893	58313	130429	227091	514806	901651
1050	14898	36614	61190	136864	238296	540206	946139
1100	15599	38336	64067	143300	249500	565607	990627
1150	16299	40058	66944	149735	260705	591008	1035115
1200	17000	41779	69821	156171	271910	616409	1079603
1250	17700	43501	72699	162606	283115	641810	1124091
1300	18401	45222	75576	169042	294320	667211	1168579
1350	19101	46944	78453	175477	305525	692612	1213067
1400	19802	48666	81330	181913	316729	718012	1257555
1450	20503	50387	84207	188348	327934	743413	1302043
1500	21203	52109	87085	194784	—	—	—
1550	21904	53831	89962	201219	—	—	—
1600	22604	55552	92839	207655	—	—	—
1650	23305	57274	95716	214090	—	—	—
1700	24005	58996	98593	220525	—	—	—
1750	24706	60717	101471	226961	—	—	—
1800	25406	62439	104348	233396	—	—	—
1850	26107	64161	107225	239832	—	—	—
1900	26807	65882	110102	246267	—	—	—
2000	28209	69325	115857	259138	—	—	—
2100	29610	72769	121611	272009	—	—	—
2200	31011	76212	127366	284880	—	—	—
2300	32412	79655	133120	297751	—	—	—
2400	33813	83099	138874	310622	—	—	—
2500	35214	86542	144629	323493	—	—	—
2600	36615	89985	150383	336364	—	—	—
2700	38016	93429	156138	349235	—	—	—
2800	39417	96872	161892	362106	—	—	—
2900	40818	100315	167646	374977	—	—	—
3000	42219	103758	173401	387848	—	—	—
3500	49225	120975	202173	452202	—	—	—
4000	56230	138191	230945	516557	—	—	—
4500	63236	155408	259717	—	—	—	—
5000	70241	172624	288489	—	—	—	—
5500	77247	189841	317261	—	—	—	—
6000	84252	207057	346033	—	—	—	—
6170	86634	212911	355816	—	—	—	—

- General Notes:**
1. Minimum set pressure for 1" x 2" size valves in any orifice is 20 psig.
 2. Capacities based on a specific gravity of 0.65 at a temperature of 60°F.
 3. Capacities at 30 psig and below are based on 3 psi overpressure.



Water Capacities: API Nozzle, 10% Overpressure

ASME PRESSURE VESSEL CODE (UV) CAPACITIES IN US GALLONS PER MINUTE AT 70°F

Set Pressure (psig)	Orifice Area, Sq. Inches													
	D	E	F	G	H	J	K	L	M	N	P	Q	R	T
	0.110	0.196	0.307	0.503	0.785	1.287	1.838	2.853	3.60	4.34	6.38	11.05	16.0	26.0
15	18.9	28.3	46.7	70.4	110	180	257	399	504	607	893	1546	2241	3648
20	21.3	32.0	52.8	79.6	124	203	291	451	570	687	1009	1748	2533	4124
30	25.6	38.4	63.3	95.4	149	244	348	541	682	823	1209	2094	3035	4940
40	29.5	44.3	73.1	110	172	281	402	624	788	950	1396	2418	3504	5704
50	33.0	49.5	81.7	123	192	315	450	698	881	1062	1561	2703	3918	6377
60	36.2	54.3	89.5	134	210	345	492	765	965	1164	1710	2962	4292	6986
70	39.1	58.6	96.7	145	227	372	532	826	1042	1257	1847	3199	4636	7546
80	41.8	62.7	103	155	243	398	569	883	1115	1344	1975	3420	4956	8067
90	44.3	66.5	109	165	258	422	603	937	1182	1425	2095	3627	5256	8556
100	46.7	70.1	115	174	272	445	636	987	1246	1502	2208	3824	5541	9019
150	57.2	85.8	141	213	333	545	779	1209	1526	1840	2705	4683	6786	11046
200	66.1	99.1	163	246	384	630	900	1397	1762	2125	3123	5407	7836	12755
250	73.9	110	182	275	430	704	1006	1562	1971	2376	3492	6046	8761	14260
300	80.9	121	200	301	471	771	1102	1711	2159	2602	3825	6623	9597	15621
350	87.4	131	216	325	509	833	1190	1848	2332	2811	4132	7154	10366	16873
400	93.4	140	231	348	544	891	1272	1975	2493	3005	4417	7648	11082	18038
450	99.1	148	245	369	577	945	1350	2095	2644	3187	4685	8111	11754	19132
500	104	156	258	389	608	996	1423	2209	2787	3360	4938	8550	12390	20167
550	109	164	271	408	638	1045	1492	2316	2923	3524	5179	8968	12995	21152
600	114	171	283	426	666	1091	1558	2419	3053	3681	5410	9366	13573	22092
650	119	178	294	444	693	1136	1622	2518	3178	3831	5631	9749	14127	22994
700	123	185	305	460	719	1179	1683	2613	3298	3976	5843	10117	14660	23862
750	128	192	316	477	745	1220	1742	2705	3414	4115	6048	10472	15175	24700
800	132	198	327	492	769	1260	1800	2794	3525	4250	6247	10815	15672	25510
850	136	204	337	507	793	1299	1855	2880	3634	4381	6439	11148	16155	26295
900	140	210	346	522	816	1336	1909	2963	3739	4508	6626	11472	16623	27057
950	144	216	356	536	838	1373	1961	3045	3842	4631	6807	11786	17079	27799
1000	147	221	365	550	860	1409	2012	3124	3942	4752	6984	12092	17522	28521
1050	151	227	374	564	881	1444	2062	3201	4039	4869	7156	12391	17955	29225
1100	155	232	383	577	902	1478	2110	3276	4134	4984	7325	12682	18378	29913
1150	158	237	392	590	922	1511	2158	3350	4227	5096	7490	12967	18791	30585
1200	161	242	400	603	942	1543	2204	3422	4318	5205	7651	13246	19195	31243
1250	165	247	408	615	961	1575	2250	3492	4407	5313	7808	13519	19591	31887
1300	168	252	416	628	980	1606	2294	3562	4494	5418	7963	13787	19979	32519
1350	171	257	424	640	999	1637	2338	3629	4580	5521	8115	14050	20359	33138
1400	174	262	432	651	1018	1667	2381	3696	4664	5622	8264	14308	20733	33747
1450	178	267	440	663	1036	1697	2423	3761	4746	5722	8410	14561	21100	34344
1500	181	271	447	674	1053	1726	2464	3826	—	—	—	—	—	—
1550	184	276	455	685	1071	1754	2505	3889	—	—	—	—	—	—
1600	186	280	462	696	1088	1782	2545	3951	—	—	—	—	—	—
1650	189	284	469	707	1105	1810	2585	4013	—	—	—	—	—	—
1700	192	289	476	718	1121	1837	2623	4073	—	—	—	—	—	—
1750	195	293	483	728	1138	1864	2662	4132	—	—	—	—	—	—
1800	198	297	490	739	1154	1890	2700	4191	—	—	—	—	—	—
1850	201	301	497	749	1170	1916	2737	4249	—	—	—	—	—	—
1900	203	305	503	759	1185	1942	2773	4306	—	—	—	—	—	—
2000	209	313	517	779	1216	1993	2846	4418	—	—	—	—	—	—
2100	214	321	529	798	1246	2042	2916	4527	—	—	—	—	—	—
2200	219	328	542	817	1276	2090	2984	4633	—	—	—	—	—	—
2300	224	336	554	835	1304	2137	3052	4738	—	—	—	—	—	—
2400	229	343	566	853	1332	2183	3117	4839	—	—	—	—	—	—
2500	233	350	578	871	1360	2228	3181	4939	—	—	—	—	—	—
2600	238	357	589	888	1387	2272	3245	5037	—	—	—	—	—	—
2700	242	364	600	905	1413	2315	3306	5133	—	—	—	—	—	—
2800	247	371	611	921	1439	2358	3367	5227	—	—	—	—	—	—
2900	251	377	622	938	1465	2399	3427	5320	—	—	—	—	—	—
3000	256	384	633	954	1490	2441	3485	5411	—	—	—	—	—	—
3500	276	414	684	1030	1609	2636	3764	5844	—	—	—	—	—	—
4000	295	443	731	1101	1720	2818	4024	6248	—	—	—	—	—	—
4500	313	470	775	1168	1825	2989	—	—	—	—	—	—	—	—
5000	330	495	817	1231	1923	3151	—	—	—	—	—	—	—	—
5500	346	520	857	1292	2017	3305	—	—	—	—	—	—	—	—
6000	362	543	895	1349	2107	3452	—	—	—	—	—	—	—	—
6170	367	550	908	1368	2137	3500	—	—	—	—	—	—	—	—

General Notes:

- Capacities at 30 psig and below are based on 3 psi overpressure.

Numbering System

38	D	C	1															
Series Number	Orifice Area		Construction	Temperatures & Materials														
38	Designation & Orifice Letter	API Orifice Area Sq. In.	Actual Orifice Area Sq. In.															
	D	0.110	0.150	<p>C Elastomer O-Ring Seat Seal</p> <p>T Teflon O-Ring* Seat & Seals (Main Valve Only)</p> <p>*For cryogenic applications to -450° F, add S4 to the type number. Consult the Factory.</p>														
	E	0.196	0.225															
	F	0.307	0.371															
	G	0.503	0.559															
	H	0.785	0.873															
	J	1.287	1.430															
	K	1.838	2.042															
	L	2.853	3.170															
	M	3.60	4.000															
	N	4.34	4.822															
	P	6.38	7.087															
	Q	11.05	12.27															
	R	16.00	17.78															
	T	26.00	28.94															
	A	—	0.719															
	1	—	1.767															
	2	—	2.953															
	3	—	6.605															
	4	—	11.50															
	6	—	26.07															
	8	—	45.66															
				<table border="1"> <thead> <tr> <th rowspan="2" style="font-weight: bold;">Designation</th> <th rowspan="2" style="font-weight: bold;">Inlet Temperature Range °F</th> <th colspan="2" style="font-weight: bold;">Material</th> </tr> <tr> <th style="font-weight: bold;">Body & Cover</th> <th style="font-weight: bold;">Spring</th> </tr> </thead> <tbody> <tr> <td style="text-align: center;">1</td> <td style="text-align: center;">-20 to 450</td> <td style="text-align: center;">Carbon Steel</td> <td style="text-align: center;">Stainless Steel</td> </tr> <tr> <td style="text-align: center;">1</td> <td style="text-align: center;">-20 to -450</td> <td style="text-align: center;">Consult Factory</td> <td style="text-align: center;">Consult Factory</td> </tr> </tbody> </table>	Designation	Inlet Temperature Range °F	Material		Body & Cover	Spring	1	-20 to 450	Carbon Steel	Stainless Steel	1	-20 to -450	Consult Factory	Consult Factory
Designation	Inlet Temperature Range °F	Material																
		Body & Cover	Spring															
1	-20 to 450	Carbon Steel	Stainless Steel															
1	-20 to -450	Consult Factory	Consult Factory															

To simplify the selection and specifying of Farris pressure relief valves, use the following type numbering system. The type numbering system is ideal as the digits which comprise a specific type number have a distinct significance. The digits describe the basic valve series, orifice, seat and internal construction, inlet temperature range, body, and spring material, inlet flange class as well as Code liquid design.

Ordering Information

To properly process your order and avoid delay please specify the following:

1. Quantity
2. Inlet and Outlet Size.
3. Farris Type Number*.
4. Inlet and Outlet Flange Class and Facing.
5. Materials of Construction, if other than Standard.
6. O-Ring Seal Material (Viton is Standard).
7. Set Pressure*.
8. Maximum Inlet Temperature*.
9. Allowable Overpressure*.
10. Fluid and Fluid State*.
11. Backpressure, Superimposed Constant and/or Variable and Built-up*.
12. Required Capacity*.
13. Physical Properties of Fluid (Molecular Wt., Specific Gravity, etc.).
14. Accessories
 - a) Manual or Remote Blowdown
 - b) Field Test Connection
 - c) Reverse Flow Preventer
 - d) Auxiliary Filters
15. Code Requirements, if any.

* As a customer service we verify your selection and sizing. If this service is desired, you must include this information.

Note: If valve modification or set pressure changes are required, consideration must be given to correct the nameplate and other data.

2		X -	1	2	0	/S4													
Inlet Class		Special Construction	Inlet Facing	Pilot Control	Options	Special Material													
<table border="1"> <thead> <tr> <th>Designation</th> <th>ANSI Nominal Inlet Flange Class</th> </tr> </thead> <tbody> <tr> <td>0</td> <td>150</td> </tr> <tr> <td>2</td> <td>300</td> </tr> <tr> <td>3</td> <td>600</td> </tr> <tr> <td>4</td> <td>900</td> </tr> <tr> <td>5</td> <td>1500</td> </tr> <tr> <td>6</td> <td>2500</td> </tr> </tbody> </table>	Designation	ANSI Nominal Inlet Flange Class	0	150	2	300	3	600	4	900	5	1500	6	2500	(If applicable) L -Liquid Service (Standard Connections) X -Air & Vapor Service (Oversize Connections) Y -Liquid Service (Oversize Connections) D -Air & Vapor Service (Dual Outlet) ¹ E -Liquid Service (Dual Outlet) ¹	Special0 Raised Face, ANSI Std. (125 to 160 AARH)1 Ring Joint ANSI Std. (Octagonal)9 63 AARH Smooth Finish RF H Although not applicable to the inlet facing only, the following first digit letters are also used: 63 to 83 AARH (Outlet only)J 63 to 83 AARH (Inlet and outlet) K	Snap Acting Pilot Control2 Modulating Pilot Control M	No Options0 Dual Pilot Controls2 Auxiliary Filter3 Manual Depressurizing4 Field Test Connections5 Automatic Reverse Flow Preventer6 Pressure Spike Snubbers7 Remote Depressurizing8 Four Auxiliary Functions*9 Specify Combination of Options Following Complete Type NumberC Remote Sensing R	S4 Complete 316 St. St. S7 NACE Construction
	Designation	ANSI Nominal Inlet Flange Class																	
	0	150																	
	2	300																	
	3	600																	
	4	900																	
	5	1500																	
6	2500																		
		<i>1. Available on 6" and 8" inlet size valves only.</i>																	

* Includes a combination of 4, 5, 6 & 8.

Parts Replacement

Valves: If an exact replacement valve is required, the valve type, size and serial number must be specified to assure proper dimensions and material being supplied. If a specific valve has become obsolete, a recommendation for the current equivalent, if any, will be made.

Spare Parts: When ordering parts, use part names as listed in the bills of material in this catalog. Specify valve type, size and serial number. If serial number is not available, the original Farris factory order number will assist in our supplying the proper part and material.

Springs: Order as an assembly to include spring with upper and lower spring buttons. Specify valve type, size, serial number, set pressure and back pressure, if any.

Guarantee

All products manufactured by Farris Engineering are warranted free of defects in material and workmanship when used within the range recommended for a period of one year after installation or eighteen months from delivery. When authorized, any defective product may be returned to the factory and if found defective will be repaired or replaced free of charge, solely at the discretion of Farris Engineering, ex-works our factory. No charge for labor or other expense incurred will be allowed, as the liability of Farris Engineering is measured by the refund price of the defective product only. All warranties are based on the product being used within the range recommended.

This warranty does not cover the performance of valves tested at site on test equipment that is not to the same technical standard as that used by the manufacturer.

Sizing Information



The 3800 Series pilot operated valves are built in conformance to Section VIII of the ASME Boiler and Pressure Vessel Code for air, gas, vapor and liquid services. Sizing is per the equations listed below.

For Air, Gas & Vapor Service: (SCFM)

For Vapor or Gas Service: (Lbs./hr.)

For Liquid Service: (G.P.M.)

$$A = \frac{V\sqrt{G}\sqrt{T}\sqrt{Z}}{1.175CK_dPK_b}$$

$$A = \frac{W\sqrt{T}\sqrt{Z}}{CK_dP\sqrt{MK_b}}$$

$$A = \frac{V_L\sqrt{G}}{38.0K_d\sqrt{\Delta}PK_u}$$

Where:

- A = Required orifice area in square inches
- V = Required gas capacity in SCFM
- W = Required vapor capacity in pounds per hour
- V_L = Required liquid capacity in U.S. gallons per minute
- P = Relieving pressure in pounds per square inch absolute = set pressure + overpressure + 14.7 psig where the overpressure is 10% or 3 psig, whichever is greater. P = 1.10 x set pressure + 14.7 psig or P = set pressure + 3 psig + 14.7 psig
- ΔP = Set pressure + overpressure – back pressure in psig
- T = Inlet temperature, absolute (°F plus 460)
- C = Gas or vapor flow constant
- M = Average molecular weight of vapor
- G = Specific gravity of gas or liquid at actual discharge temperature
- Z = Compressibility factor corresponding to T and P. If this factor is not available, compressibility correction can be safely ignored using a value of Z = 1.0
- K_b = Back pressure correction factor (air, gas & vapor only)
- K_d = Coefficient of discharge (Note 1)

	ASME (actual)	API (effective)
Air, gas & vapor service, API Full Nozzle Design.....	0.859.....	0.954
Air, gas & vapor service, Full Port Design.....	0.801.....	n/a
Liquid service, API Full Nozzle Design Only	0.782.....	0.869

General Notes:

1. When sizing and selecting valves by the API orifice areas, use the API coefficient of discharge in the equation.

Back Pressure Sizing Factor K_b

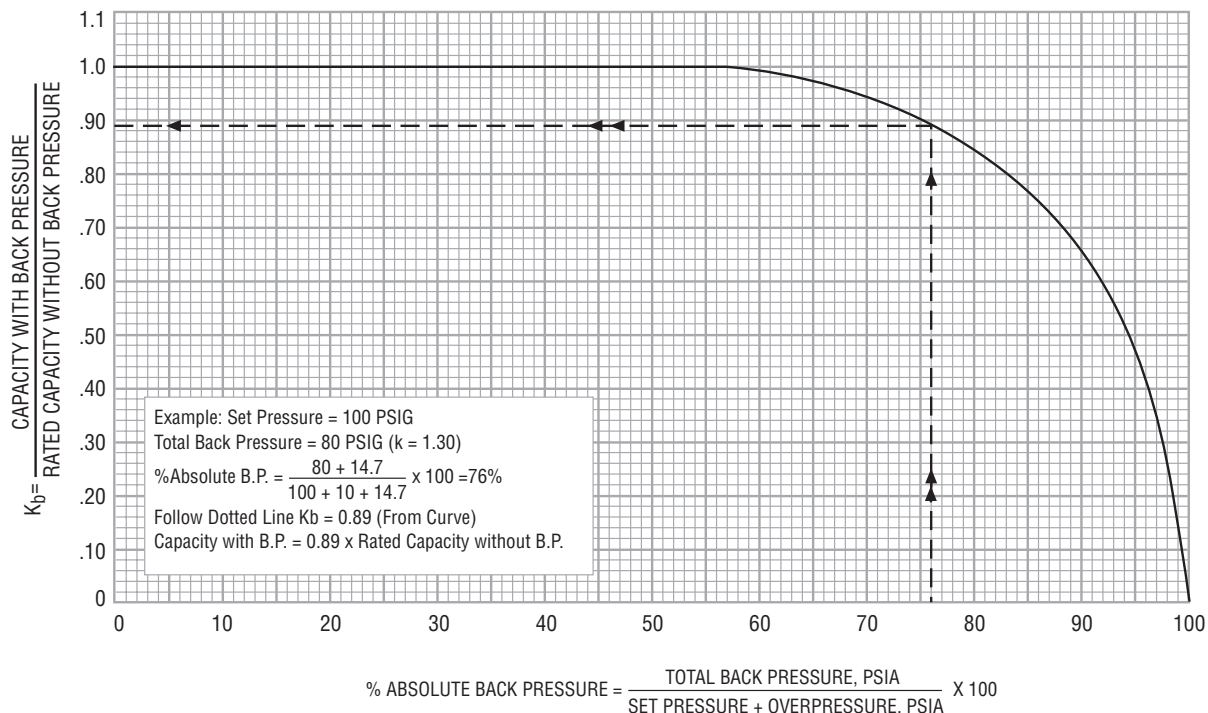

A full line of accessories is available to meet your service requirements.

Manual or Remote Blowdown: the main valve can be cycled to the open position by venting the pressure in the dome above the piston. The optional manual valve for this purpose mounts directly on the main valve. By installing a solenoid valve, the main valve can be cycled remotely. Neither the manual or remote blowdown system will interfere with the normal overpressure protection provided by the main valve and pilot.

Reverse Flow Preventer: in a system where back pressure exceeds system pressure, it is possible for the main valve to open and allow flow from the discharge system to enter the inlet side. A reverse flow preventer assures that the back pressure, as a minimum, is maintained in the dome area so that the main valve remains closed.

Field Test Connection: the set pressure of Farris pilot operated relief valves can be verified without interrupting system protection and does not require overpressure of the system. An auxiliary source of pressure, such as a nitrogen bottle, is connected to the pilot sensing line through a stop valve. Pressure applied to the pilot valve reacts the way it would if the pilot were sensing overpressure in the main valve sensing line. A check valve restricts the source pressure from back-flowing into the main inlet. Both pilot and main valves will cycle at set pressure, verifying the set pressure and validating that the system is in compliance with ASME Section VIII, UG-136(a)(3).

Spike Snubbers: a spike snubber installed in the pilot valve sensing line will eliminate the negative effects of pressure pulsation caused by a positive displacement compressor. It assures that the pilot valve is sensing and reacting to mean pressure to protect the system and not to cyclic pressure that can be caused by a compressor.

Auxiliary Filters: every PCF3 pilot valve is manufactured with an internal filter to reduce the flow of erosive particles through the pilot control. Auxiliary filters for the pilot valve sensing line are available to complement the internal filter for special services.

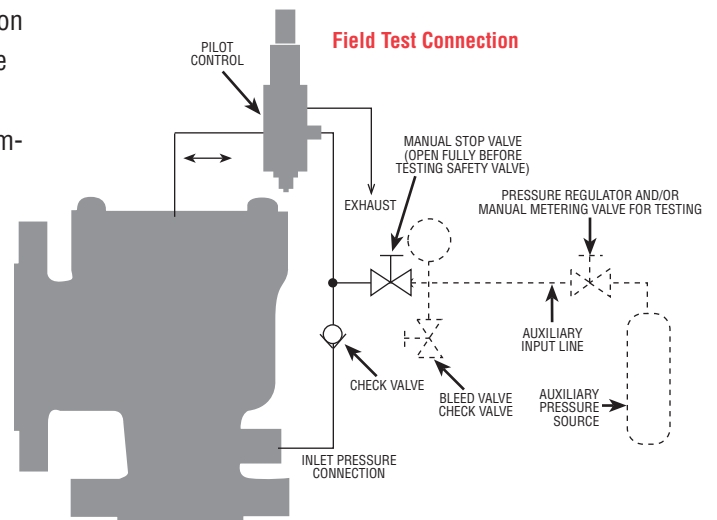
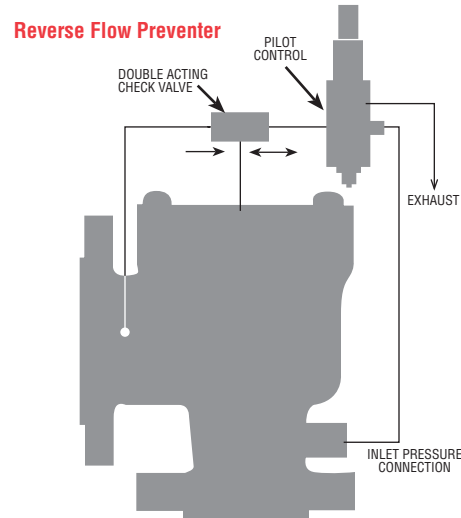
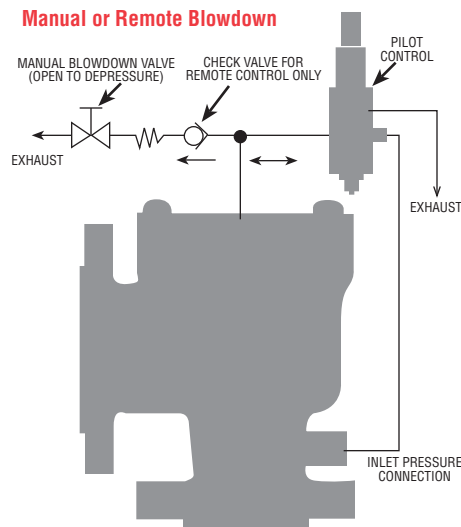

Dimensions and Weights: API Nozzle



Valve Size Inlet x Outlet	Type Number	ANSI Flange Class		Dimension (Inches)					Approx. Weight Lbs.
		Inlet RF	Outlet RF	A	B	C	E	F	
1 x 2	38DC10-120	150#	150#	12 1/8	4 1/2	4 1/8	1/16	11/16	30
	38DC12-120	300#		12 3/8	4 1/2	4 3/8	1/16	15/16	30
	38DC13-120	600#		12 3/8	4 1/2	4 3/8	1/4	15/16	30
	38DC14-120	900#	300#	12 7/8	4 3/4	4 15/16	1/4	1 7/16	49
	38DC15-120	1500#		12 7/8	4 3/4	4 15/16	1/4	1 7/16	49
	38DC16-120	2500#		13	4 3/4	4 15/16	1/4	1 11/16	55
1 x 2	38EC10-120	150#	150#	12 1/8	4 1/2	4 1/8	1/16	11/16	30
	38EC12-120	300#		12 3/8	4 1/2	4 3/8	1/16	15/16	30
	38EC13-120	600#		12 3/8	4 1/2	4 3/8	1/4	15/16	30
	38EC14-120	900#	300#	12 7/8	4 3/4	4 15/16	1/4	1 7/16	49
	38EC15-120	1500#		12 7/8	4 3/4	4 15/16	1/4	1 7/16	49
	38EC16-120	2500#		13	4 3/4	4 15/16	1/4	1 11/16	55
1 x 2	38FC10-120	150#	150#	12 1/8	4 1/2	4 1/8	1/16	11/16	30
	38FC12-120	300#		12 3/8	4 1/2	4 3/8	1/16	15/16	30
	38FC13-120	600#		12 3/8	4 1/2	4 3/8	1/4	15/16	30
	38FC14-120	900#	300#	12 7/8	4 3/4	4 15/16	1/4	1 7/16	49
	38FC15-120	1500#		12 7/8	4 3/4	4 15/16	1/4	1 7/16	49
	38FC16-120	2500#		13	4 3/4	4 15/16	1/4	1 11/16	55
1 1/2 x 2	38DC10X-120	150#	150#	13 1/2	4 3/4	4 7/8	1/16	1 1/8	32
	38DC12X-120	300#		13 1/2	4 3/4	4 7/8	1/16	1 1/8	32
	38DC13X-120	600#		13 1/2	4 3/4	4 7/8	1/4	1 1/8	32
	38DC14X-120	900#	300#	14 1/2	5 1/2	5 7/8	1/4	1 9/16	71
	38DC15X-120	1500#		14 1/2	5 1/2	5 7/8	1/4	1 9/16	71
	38DC16X-120	2500#		14 5/8	5 1/2	5 7/8	1/4	2 1/8	85
1 1/2 x 2	38EC10X-120	150#	150#	13 1/2	4 3/4	4 7/8	1/16	1 1/8	32
	38EC12X-120	300#		13 1/2	4 3/4	4 7/8	1/16	1 1/8	32
	38EC12X-120	600#		13 1/2	4 3/4	4 7/8	1/4	1 1/8	32
	38EC14X-120	900#	300#	14 1/2	5 1/2	5 7/8	1/4	1 9/16	71
	38EC15X-120	1500#		14 1/2	5 1/2	5 7/8	1/4	1 9/16	71
	38EC16X-120	2500#		14 5/8	5 1/2	5 7/8	1/4	2 1/8	85
1 1/2 x 2	38FC10X-120	150#	150#	13 1/2	4 3/4	4 7/8	1/16	1 1/8	32
	38FC12X-120	300#		13 1/2	4 3/4	4 7/8	1/16	1 1/8	32
	38FC13X-120	600#		13 1/2	4 3/4	4 7/8	1/4	1 1/8	32
	38FC14X-120	900#	300#	14 1/2	5 1/2	5 7/8	1/4	1 9/16	71
	38FC15X-120	1500#		14 1/2	5 1/2	5 7/8	1/4	1 9/16	71
	38FC16X-120	2500#		14 5/8	5 1/2	5 7/8	1/4	2 1/8	85
1 1/2 x 3	38GC10-120	150#	150#	13 1/2	4 7/8	5 1/8	1/16	1 3/16	40
	38GC12-120	300#		13 1/2	4 7/8	5 1/8	1/16	1 3/16	40
	38GC13-120	600#		13 1/2	4 7/8	5 1/8	1/4	1 3/16	42
	38GC14-120	900#	300#	14 3/4	6 3/4	6 3/8	1/4	1 9/16	81
	38GC15-120	1500#		14 3/4	6 3/4	6 3/8	1/4	1 9/16	81
	38GC16-120	2500#		14 7/8	6 3/4	6 3/8	1/4	2 1/8	96
1 1/2 x 3	38HC10-120	150#	150#	13 1/2	4 7/8	5 1/8	1/16	1 3/16	40
	38HC12-120	300#		13 1/2	4 7/8	5 1/8	1/16	1 3/16	40
	38HC13-120	600#		13 1/2	4 7/8	5 1/8	1/4	1 3/16	42
	38HC14-120	900#	300#	14 3/4	6 3/4	6 3/8	1/4	1 9/16	81
	38HC15-120	1500#		14 3/4	6 3/4	6 3/8	1/4	1 9/16	81
	38HC16-120	2500#		14 7/8	6 3/4	6 3/8	1/4	2 1/8	96
2 x 3	38GC10X-120	150#	150#	14 1/2	4 7/8	5 3/8	1/16	1 1/4	45
	38GC12X-120	300#		14 1/2	4 7/8	5 3/8	1/16	1 1/4	55
	38GC13X-120	600#		14 1/2	4 7/8	5 3/8	1/4	1 1/4	75
	38GC14X-120	900#	300#/600#	15 5/8	6 3/4	6 9/16	1/4	1 7/8	102
	38GC15X-120	1500#		15 5/8	6 3/4	6 9/16	1/4	1 7/8	102
	38GC16X-120	2500#		16 1/4	6 3/4	7	1/4	2 3/8	124
2 x 3	38HC10X-120	150#	150#	14 1/2	4 7/8	5 3/8	1/16	1 1/4	45
	38HC12X-120	300#		14 1/2	4 7/8	5 3/8	1/16	1 1/4	55
	38HC13X-120	600#		14 1/2	4 7/8	5 3/8	1/4	1 1/4	75
	38HC14X-120	900#	300#/600#	15 5/8	6 3/4	6 9/16	1/4	1 7/8	102
	38HC15X-120	1500#		15 5/8	6 3/4	6 9/16	1/4	1 7/8	102
	38HC16X-120	2500#		16 1/4	6 3/4	7	1/4	2 3/8	124



Dimensions and Weights: API Nozzle

Valve Size Inlet x Outlet	Type Number	ANSI Flange Class		Dimension (Inches)					Approx. Weight Lbs.
		Inlet RF	Outlet RF	A	B	C	E	F	
2 x 3	38JC10-120	150#	150#	14 1/2	4 7/8	5 3/8	1/16	1 1/4	45
	38JC12-120	300#		14 1/2	4 7/8	5 3/8	1/16	1 1/4	55
	38JC13-120	600#		14 1/2	4 7/8	5 3/8	1/4	1 1/4	75
	38JC14-120	900#	300#/600#	15 5/8	6 3/4	6 9/16	1/4	1 7/8	102
	38JC15-120	1500#		15 5/8	6 3/4	6 9/16	1/4	1 7/8	102
	38JC16-120	2500#		16 1/4	6 3/4	7	1/4	2 3/8	124
3 x 4	38JC10X-120	150#	150#	17 1/8	6 3/8	6 1/8	1/16	1 1/4	85
	38JC12X-120	300#		17 1/8	6 3/8	6 1/8	1/16	1 1/4	95
	38JC13X-120	600#		17 3/8	6 3/8	6 3/8	1/4	1 1/2	100
	38JC14X-120	900#	300#	18 5/8	7 1/8	7 1/2	1/4	2 1/4	172
	38JC15X-120	1500#		18 5/8	7 1/8	7 1/2	1/4	2 1/4	187
	38JC16X-120	2500#		19 1/4	7 1/8	7 3/4	1/4	2 3/4	200
3 x 4	38KC10-120	150#	150#	17 1/8	6 3/8	6 1/8	1/16	1 1/4	95
	38KC12-120	300#		17 1/8	6 3/8	6 1/8	1/16	1 1/4	105
	38KC13-120	600#		17 3/8	6 3/8	6 3/8	1/4	1 1/2	110
	38KC14-120	900#	300#	18 5/8	7 1/8	7 1/2	1/4	2 1/4	172
	38KC15-120	1500#		18 5/8	7 1/8	7 1/2	1/4	2 1/4	187
	38KC16-120	2500#		19 1/4	7 1/8	7 3/4	1/4	2 3/4	200
3 x 4	38LC10-120	150#	150#	17 1/8	6 3/8	6 1/8	1/16	1 1/4	105
	38LC12-120	300#		17 1/8	6 3/8	6 1/8	1/16	1 1/4	115
	38LC13-120	600#		17 3/8	6 3/8	6 3/8	1/4	1 1/2	125
	38LC14-120	900#	300#	18 5/8	7 1/8	7 1/2	1/4	2 1/4	172
	38LC15-120	1500#		18 5/8	7 1/8	7 1/2	1/4	2 1/4	187
	38LC16-120	2500#		19 1/4	7 1/8	7 3/4	1/4	2 3/4	200
4 x 6	38LC10X-120	150#	150#	19 3/4	8 1/4	7 3/4	1/16	1 3/4	120
	38LC12X-120	300#		19 3/4	8 1/4	7 3/4	1/16	1 3/4	140
	38LC13X-120	600#		19 3/4	8 1/4	7 3/4	1/4	1 3/4	145
4 x 6	38MC10-120	150#	150#	19 3/4	8 1/4	7 3/4	1/16	1 3/4	130
	38MC12-120	300#		19 3/4	8 1/4	7 3/4	1/16	1 3/4	140
	38MC13-120	600#		19 3/4	8 1/4	7 3/4	1/4	1 3/4	150
4 x 6	38NC10-120	150#	150#	19 3/4	8 1/4	7 3/4	1/16	1 3/4	130
	38NC12-120	300#		19 3/4	8 1/4	7 3/4	1/16	1 3/4	140
	38NC13-120	600#		19 3/4	8 1/4	7 3/4	1/4	1 3/4	155
4 x 6	38PC10-120	150#	150#	19 3/4	8 1/4	7 3/4	1/16	1 3/4	130
	38PC12-120	300#		19 3/4	8 1/4	7 3/4	1/16	1 3/4	140
	38PC13-120	600#		19 3/4	8 1/4	7 3/4	1/4	1 3/4	155
6 x 8	38QC10-120	150#	150#	24 1/8	9 1/2	9 7/16	1/16	1 7/8	200
	38QC12-120	300#		24 1/8	9 1/2	9 7/16	1/16	1 7/8	220
	38QC13-120	600#		24 3/8	9 1/2	9 11/16	1/4	2 1/4	270
6 x 8	38RC10-120	150#	150#	24 1/8	9 1/2	9 7/16	1/16	1 7/8	230
	38RC12-120	300#		24 1/8	9 1/2	9 7/16	1/16	1 7/8	270
	38RC13-120	600#		24 3/8	9 1/2	9 11/16	1/4	2 1/4	300
8 x 10	38TC10-120	150#	150#	28 1/2	11	10 7/8	1/16	1 5/8	450
	38TC12-120	300#		28 1/2	11	10 7/8	1/16	1 5/8	500
	38TC13-120	600#		29 3/8	11	11 11/16	1/4	2 3/16	700

General Notes:

1. For liquid service valves with standard size connections (L in the type number), use the standard type number dimensions, i.e. 38HC10-120. For liquid service valves with oversize connections (Y in the type number), use the oversize type number dimensions, i.e. 38DC10X-120.
2. Valves with ring joint inlet connections available on application only. Consult the Factory.
3. For modulating valves, add 2 1/2" to the A dimension.

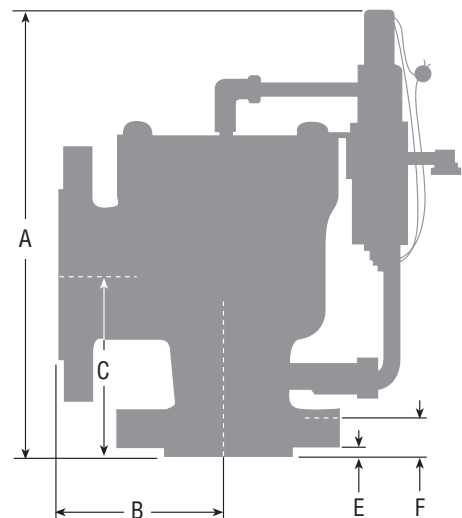

3800 Series Full Port Design: Dimensions & Weights



Valve Size Inlet x Outlet	Type Number	ANSI Flange Class		Dimension (Inches)					Approx. Weight Lbs.
		Inlet RF	Outlet RF	A	B	C	E	F	
1 1/2 x 2	381C10-120	150#	150#	13 1/2	4 3/4	4 7/8	1/16	1 1/8	35
	381C12-120	300#		13 1/2	4 3/4	4 7/8	1/16	1 1/8	35
	381C13-120	600#		13 1/2	4 3/4	4 7/8	1/4	1 1/8	40
	381C14-120	900#	300#	14 1/2	5 1/2	5 7/8	1/4	1 9/16	71
	381C15-120	1500#		14 1/2	5 1/2	5 7/8	1/4	1 9/16	71
	381C16-120	2500#		14 5/8	5 1/2	5 7/8	1/4	2 1/8	85
1 1/2 x 3	381C10X-120	150#	150#	13 1/2	4 7/8	5 1/8	1/16	1 3/16	35
	381C12X-120	300#		13 1/2	4 7/8	5 1/8	1/16	1 3/16	35
	381C13X-120	600#		13 1/2	4 7/8	5 1/8	1/4	1 3/16	40
	381C14X-120	900#	300#	14 3/4	6 3/4	6 3/8	1/4	1 9/16	81
	381C15X-120	1500#		14 3/4	6 3/4	6 3/8	1/4	1 9/16	81
	381C16X-120	2500#		14 7/8	6 3/4	6 3/8	1/4	2 1/8	96
2 x 3	382C10-120	150#	150#	14 1/2	4 7/8	5 3/8	1/16	1 1/4	50
	382C12-120	300#		14 1/2	4 7/8	5 3/8	1/16	1 1/4	60
	382C13-120	600#		14 1/2	4 7/8	5 3/8	1/4	1 1/4	80
	382C14-120	900#	300#/600#	15 5/8	6 3/4	6 9/16	1/4	1 7/8	102
	382C15-120	1500#		15 5/8	6 3/4	6 9/16	1/4	1 7/8	102
	382C16-120	2500#		16 1/4	6 3/4	7	1/4	2 3/8	124
3 x 4	383C10-120	150#	150#	17 1/8	6 3/8	6 1/8	1/16	1 1/4	90
	383C12-120	300#		17 1/8	6 3/8	6 1/8	1/16	1 1/4	100
	383C13-120	600#		17 3/8	6 3/8	6 3/8	1/4	1 1/2	105
	383C14-120	900#	300#	18 5/8	7 1/8	7 1/2	1/4	2 1/4	172
	383C15-120	1500#		18 5/8	7 1/8	7 1/2	1/4	2 1/4	187
4 x 6	384C10-120	150#	150#	19 3/4	8 1/4	7 3/4	1/16	1 3/4	135
	384C12-120	300#		19 3/4	8 1/4	7 3/4	1/16	1 3/4	145
	384C13-120	600#		19 3/4	8 1/4	7 3/4	1/4	1 3/4	160
6 x 8	386C10-120	150#	150#	24 1/8	9 1/2	9 7/16	1/16	1 7/8	235
	386C12-120	300#		24 1/8	9 1/2	9 7/16	1/16	1 7/8	275
	386C13-120	600#		24 3/8	9 1/2	9 11/16	1/4	2 1/8	305
8 x 10	388C10-120	150#	150#	28 1/2	11	10 7/8	1/16	1 5/8	460
	388C12-120	300#		28 1/2	11	10 7/8	1/16	1 5/8	510
	388C13-120	600#		29 1/4	11	11 11/16	1/4	2 3/16	710

General Notes:

1. For liquid service valves with standard size connections (L in the type number), use the standard type number dimensions, i.e. 38HC10-120. For liquid service valves with oversize connections (Y in the type number), use the oversize type number dimensions, i.e. 38DC10X-120.
2. Valves with ring joint inlet connections available on application only. Consult the Factory.
3. For modulating valves, add 2 1/2" to the A dimension.

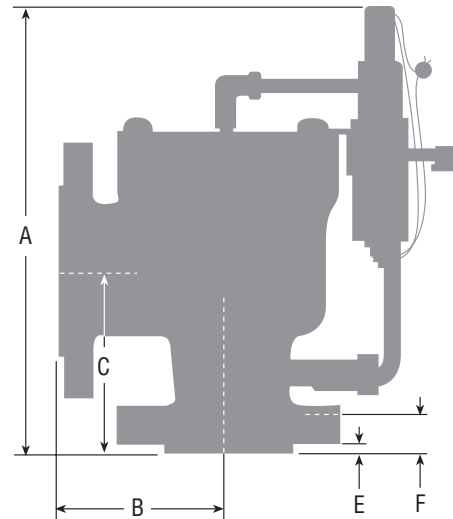

Process Pressure Relief Valves

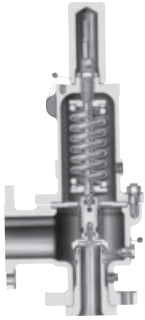

SERIES 2600/2600L

- ASME NB Certified: Air, Steam & Water
- Sizes: 1" x 2" to 20" x 24"
- Pressure Range: 15 psig to 6000 psig
- Temperature Range: -450°F to +1500°F
- Materials: Carbon Steel, Stainless, Monel & Hastelloy C
- Options: Balanced Bellows, O-Ring Seat, Open Bonnet

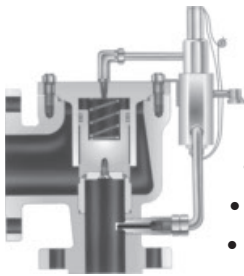

SERIES 3800 Pilot Operated

- ASME NB Certified: Air, Steam & Water
- Sizes: 1" x 2" to 12" x 16"
- Pressure Range: 15 psig to 6170 psig
- Temperature Range: -450°F to +500°F
- Materials: Steel Body & Bonnet, Stainless Steel Trim
- Options: Modulating Pilot Control, Complete 316 Stainless Steel Construction

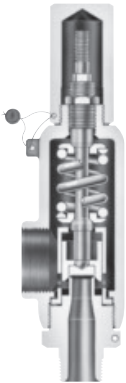

SERIES 2700

- ASME NB Certified: Air, Steam & Water
- Sizes: 1/2" x 1" to 1-1/2" x 2-1/2"
- Pressure Range: 15 psig to 6500 psig
- Temperature Range: -450°F to +750°F
- Materials: Stainless Steel Body & Trim, Carbon Steel Bonnet
- Options: Stainless Steel, Monel & Hastelloy Materials, O-Ring Seats, Flanged, Socket Weld, Welding Nipple, & Sanitary Connections

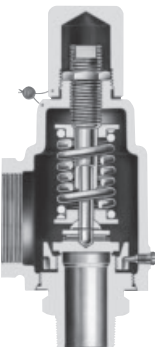

SERIES 2850/2856

- ASME NB Certified: Air & Steam
- Sizes: 3/4" x 1" to 1-1/2" x 2" (2850)
3/4" x 1-1/4" to 2" x 3" (2856)
- Pressure Range: 15 psig to 300 psig
- Temperature Range:
-20° F to +750°F (2850)
-450° F to +400°F (2856)
- Materials: Stainless Steel Body & Trim Steel Bonnet (2850)
Brass Body & Trim, Bronze Bonnet (2856)

Steam Safety Valves

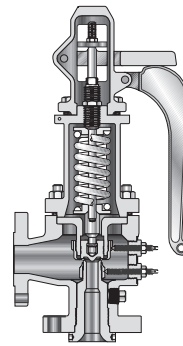

SERIES 4200

- ASME NB Section I & VIII Certified: Steam & Air
- Sizes 1 1/4" x 1 1/2" to 6" x 8"
- Pressure Range: 15 psig to 1000 psig
- Temperature Range: -20°F to +1000°F
- Materials: Carbon / Alloy St. & Stainless Steel.

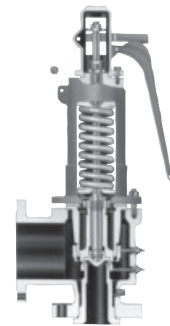

SERIES 6400/6600

- ASME NB Section I & VIII Certified: Steam & Air
- Sizes: 1" x 2" to 4" x 6"
- Pressure Range: 15 psig to 1500 psig
- Temperature Range: -20°F to +1000°F
- Materials: Carbon and Stainless Steel
- Options: Exposed Spring & Closed Bonnet

Special Purpose Pressure Relief Valves

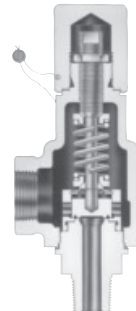

SERIES 1890/1896M

- ASME NB Certified: Air, Steam & Water
- Sizes: 1/2" x 1" & 3/4" x 1" (1890)
1/2" x 3/4" & 3/4" x 3/4" (1896M)
- Pressure Range:
15 psig to 800 psig (1890)
15 psig to 300 psig (1896M)
- Temperature Range:
-20°F to +750°F (1890)
-450°F to +400°F (1896M)
- Materials:
Stainless Steel Body & Trim (1890)
Brass Body & Trim, Bronze Bonnet (1896M)

Test Stands



MODELS T1500 & T6000

- Air & Water Testing
- Maximum Pressures of 1500 psig and 6000 psig
- Test Valves to 8" Inlet Size
- Stainless Steel Test Drum & Test Table
- Digital Test Gauge



Farris Engineering Products & Services



Process Pressure Relief Valves

Series 2600	ASME NB Certified for Air, Steam and Water
Series 2700	ASME NB Certified for Air, Steam and Water
Series 3800	ASME NB Certified for Air, Steam and Water
Series 1890/1896M	ASME NB Certified for Air, Steam and Water
Series 2850/2856	ASME NB Certified for Air and Steam
Series 69	Liquid Service
Series 88/89	ASME NB Certified for Air and Steam
Series 140	Air Service
Series 570	ASME NB Certified for Air and Steam

Steam Safety Valves

Series 4200	ASME NB Certified for Steam – Section I & VIII
Series 6400/6600	ASME NB Certified for Steam – Section I & VIII
Series 560	ASME NB Certified for Steam – Section I & VIII

The following is a list of Farris approvals currently on record:

- ASME “V”, “UV” and “NV”
- National Board “NB”
- ISO 9001-2000
- US Coast Guard
- PED 97/23/EC (European Pressure Equipment Directive)
- ATEX 94/9/EC (European Potentially Explosive Atmospheres)
- Canadian TSSA Registration
- CSQL (China Safety Quality License)
- GOST-R and GGNT (Russian Certification and Permits)
- First Point Assessment Limited

Universal Test Stand

PRV Test Stands with Air and Water Test Capability

SizeMaster™ Mark IV

Pressure Relief Valve Engineering Software for Sizing and Selection

FAST Centers (Farris Authorized Service Team)

“Understanding what the Customer wants...making it happen!”

- Worldwide Network of Service Centers with Factory Trained Technicians
- Local Inventory with 24 hour a day / 7 day a week support
- Access to Worldwide Farris Inventory through the Web
- ASME/National Board approved Assembly & Test Facilities
- Application, Sizing & Selection Support

Farris Engineering

division of Curtiss-Wright Flow Control Corporation



10195 Brecksville Road, Brecksville, OH 44141 USA • Telephone: 440-838-7690 • Fax: 440-838-7699 • www.farrisengineering.com

Facilities: Brecksville, Ohio USA; Brantford, Ontario; Edmonton, Alberta, Canada; Kettering, Northants, UK; Delhi, India; Tianjin, China

Offices Worldwide: For a listing of our global sales network, visit our website at www.farrisengineering.com.

While this information is presented in good faith and believed to be accurate, Farris Engineering, division of Curtiss-Wright Flow Control Corporation, does not guarantee satisfactory results from reliance on such information. Nothing contained herein is to be construed as a warranty or guarantee, expressed or implied, regarding the performance, merchantability, fitness or any other matter with respect to the products, nor as a recommendation to use any product or process in conflict with any patent. Farris Engineering, division of Curtiss-Wright Flow Control Corporation, reserves the right, without notice, to alter or improve the designs or specifications of the products described herein.