



Series 2700

Pressure Relief Valves



Flanged



Female NPT Inlet



Sanitary Inlet



Sanitary Inlet and Outlet



Farris Engineering

Division of Curtiss-Wright Flow Control Corporation



Series 2700 Pressure Relief Valves



Designed to provide customers with the widest selection of sizes, orifices and construction materials, Series 2700 meets the exacting demands of the process industry.

Table of Contents

General Description.....	2
Ordering Information & Numbering System.....	3
Bill of Materials-Conventional.....	4
Bill of Materials-Balanced Design.....	5
Selection Table: O-Ring Design.....	6
Selection Tables: Conventional U.S. Customary Units	
Threaded Connections.....	6
Flanged Connections.....	7
Selection Tables-Balanced Design U.S. Customary Units	
Threaded Connections.....	8
Flanged Connections.....	8
Special Materials.....	9
Capacity Tables-U.S. Customary Units	
Air.....	10
Steam.....	10
Water.....	11
Selection Tables-Conventional-Metric	
Threaded Connections.....	12
Flanged Connections.....	13
Selection Tables-Balanced Design-Metric	
Threaded Connections.....	14
Flanged Connections.....	14
Capacity Tables-Metric	
Air.....	15
Water.....	15
Steam.....	16
Cap Constructions.....	16
Dimensions & Weights.....	18
Other Farris Engineering Valves.....	19

Superior Design

- A single design handles air, steam, vapor and liquid services.
- Maximum interchangeability of parts affords easy maintenance and lower costs.
- Fixed blowdown design simplifies testing and repair. Maximum blowdown of 5% to 15% regardless of service.¹
- A built-in lift stop ensures stable performance.
- Balanced design in “C” and “D” orifices nullifies the effects of back pressure on set point.

ASME Code Certification

- Manufactured in conformance to Section VIII of the ASME Boiler and Pressure Vessel Code for air, steam, and liquid service.
- Capacities certified by The National Board of Boiler and Pressure Vessel Inspectors.

Optional O-Ring Seat Design

- O-ring seat design available for maximum seat tightness.
- Teflon® available at higher pressures to provide the same zero bubbles per minute leakage as elastomer O-ring seats.

Comprehensive Product Line

- Set pressures from 15 psig to 6500 psig with orifice areas from 0.068 to 0.573 sq. in.
- Standard valves have MNPT inlet X FNPT outlet. Optional female thread, flanged, socket weld, welding nipple, and sanitary connections available.

Maximum Selection of Materials

- Standard construction includes 316 stainless steel body, trim and spring, with carbon steel bonnet.
- Optional materials include Monel®, Hastelloy C®, and materials suitable for NACE service.

General Note:

¹Blowdown on liquid service may slightly exceed 15% in certain applications.

Teflon is a registered trademark of the DuPont Company.

Monel is a registered trademark of Inco Alloys International Inc.

Hastelloy and Hastelloy C are registered trademarks of Haynes International Inc.



Numbering System

Selecting and specifying Farris pressure relief valves is simple using the numbering system that follows. Each digit of the part number has a distinct significance. The digits describe the basic valve series, orifice, seat design, inlet temperature range, body, bonnet and spring material, inlet type and pressure rating.

27	D	A	2	3	H -	M	2	0	S4
Series Number	Orifice/Area	Seat Construction	Inlet Size ¹	Outlet Size ¹	Special Variations	Inlet Connections	Cap Construction	Test Gag	Special Materials
27	C 0.068	A Metal Seat	1 1/2"	3 1"	H High pressure variations of standard types	M MNPT	2 Plain	O No Gag	S4 Complete 316 St. St.
	D 0.125	C Soft Seat	2 3/4"	4 1 1/2"		F FNPT	4 Packed Lever	1 Test Gag	N1 NACE Trim: Standard
	E 0.223	T Teflon Seat	3 1"	5 2"		B Balanced design ²	1 Flanged -150RF	7 Open Lever	N4 NACE Trim: All St. St.
	F 0.350		4 1 1/2"	6 2 1/2"		D Heat transfer fluid standard pressure	2 Flanged -300RF		M1 Monel Body & Disc
	G 0.573					E Heat transfer fluid high pressure	3 Flanged -600RF		M2 Monel Trim
						4 Flanged -900RF	M4 Complete Monel		
						5 Flanged -1500RF		H1 Hastelloy C Body & Disc	
						6 Flanged -2500RF		H2 Hastelloy C Trim	
						O Special		H4 Complete Hastelloy C	
						S Socket Weld			
						T Sanitary			
						W Welding Nipple			

Ordering Information

Please specify the following so that we may process your order as quickly as possible.

- 1 Quantity.*
- 2 Inlet and outlet sizes.
- 3 Farris type number.*
- 4 Inlet and outlet connections: MNPT, FNPT, flanged, socket weld, sanitary inlet or weld nipple.
- 5 Materials of construction if other than standard.
- 6 O-ring seat pressure seal material, if required.
- 7 Set pressure.*
- 8 Operating and relieving temperatures.*
- 9 Allowable overpressure.*
- 10 Fluid and fluid state.*
- 11 Backpressure, superimposed constant and/or variable, and built-up.*
- 12 Required capacity.*
- 13 Accessories: open or packed lever if required; test gag.
- 14 Code requirements, if any.

*As a customer service, we verify your selection and sizing. In order to do this, we must have this information.

General Notes:

1. Not all combinations of inlet and outlet sizes shown are available. Consult the selection tables of pages 6 and 7.
2. Test gag option is not available with open lever cap.
3. Available in O-ring seat design only. Consult the Farris Factory.

Bill of Materials - Conventional



Complies with ASME Boiler & Pressure Vessel Code, Section VIII

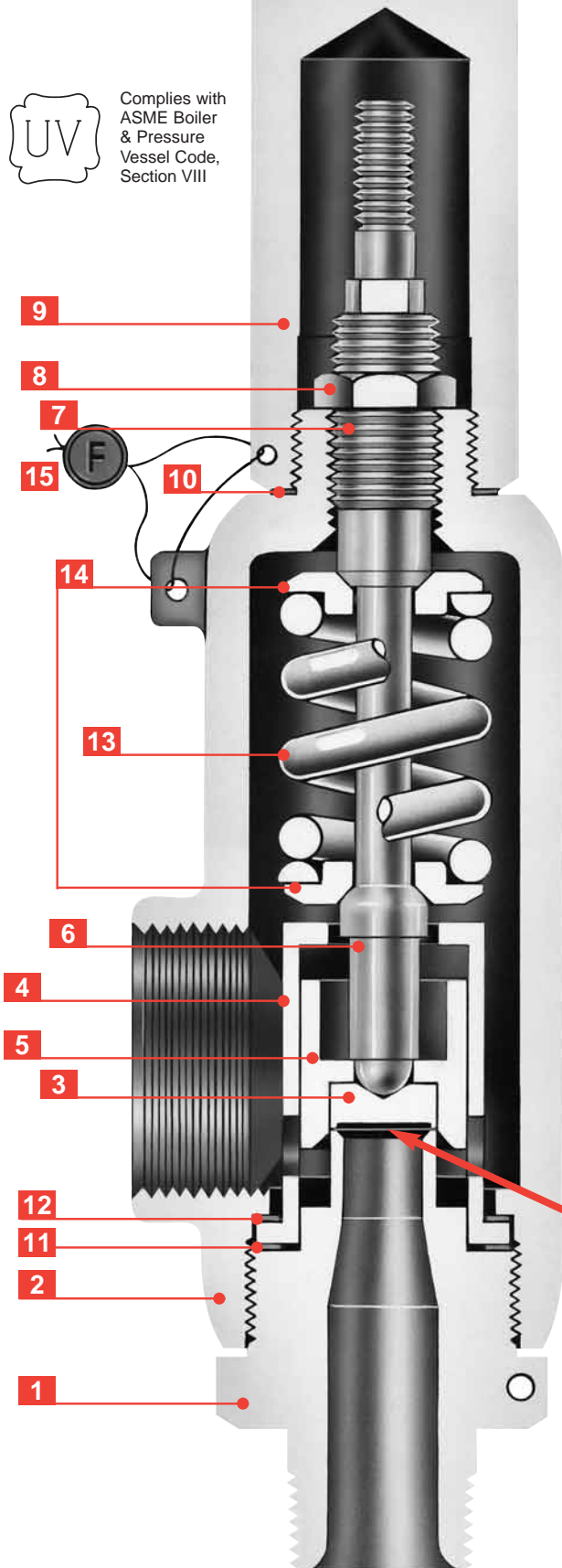

Item No.	Part Name	Standard Material
1	Body	SA-351, Gr. CF8M St. St. or SA-479 Type 316 St. St.
2	Bonnet	SA-216, Gr. WCB, Carb. St.
3	Disc	316 St. St.
4	Guide	316 St. St.
5	Disc Holder	316 St. St.
6	Stem	316 St. St.
7	Spring Adj. Screw	316 St. St.
8	Jam Nut	316 St. St.
9	Cap, Plain Screwed	Carbon Steel
10	Cap Gasket	316 St. St.
11	Body Gasket	316 St. St.
12	Guide Gasket	316 St. St.
13	Spring (-50°F to +750°F)	Stainless Steel
14	Spring Buttons	316 St. St.
15	Wire Seal	St. St. Wire / Lead Seal
16	Nameplate (Not Shown)	Stainless Steel
17	Welding Nipple (Inlet)	316 St. St.
18	Welding Nipple (Outlet)	Carbon Steel
19	Lap Joint Stub End (Inlet)	316 St. St.
20	Lap Joint Stub End (Outlet)	Carbon Steel
21	Lap Joint Flange (Inlet)	Carbon Steel
22	Lap Joint Flange (Outlet)	Carbon Steel

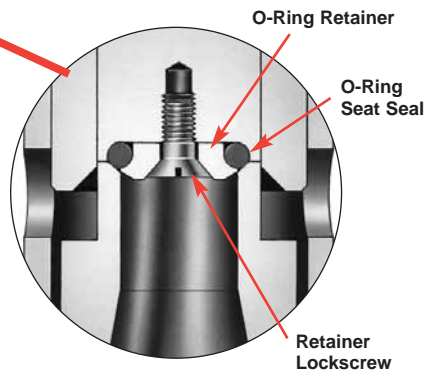

O-Ring Design (Optional)

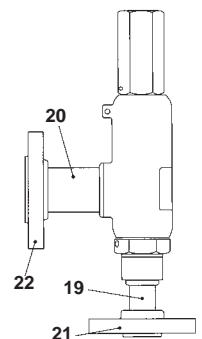
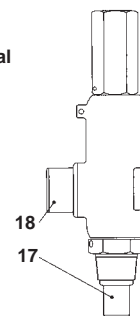



Complies with ASME Boiler & Pressure Vessel Code, Section VIII

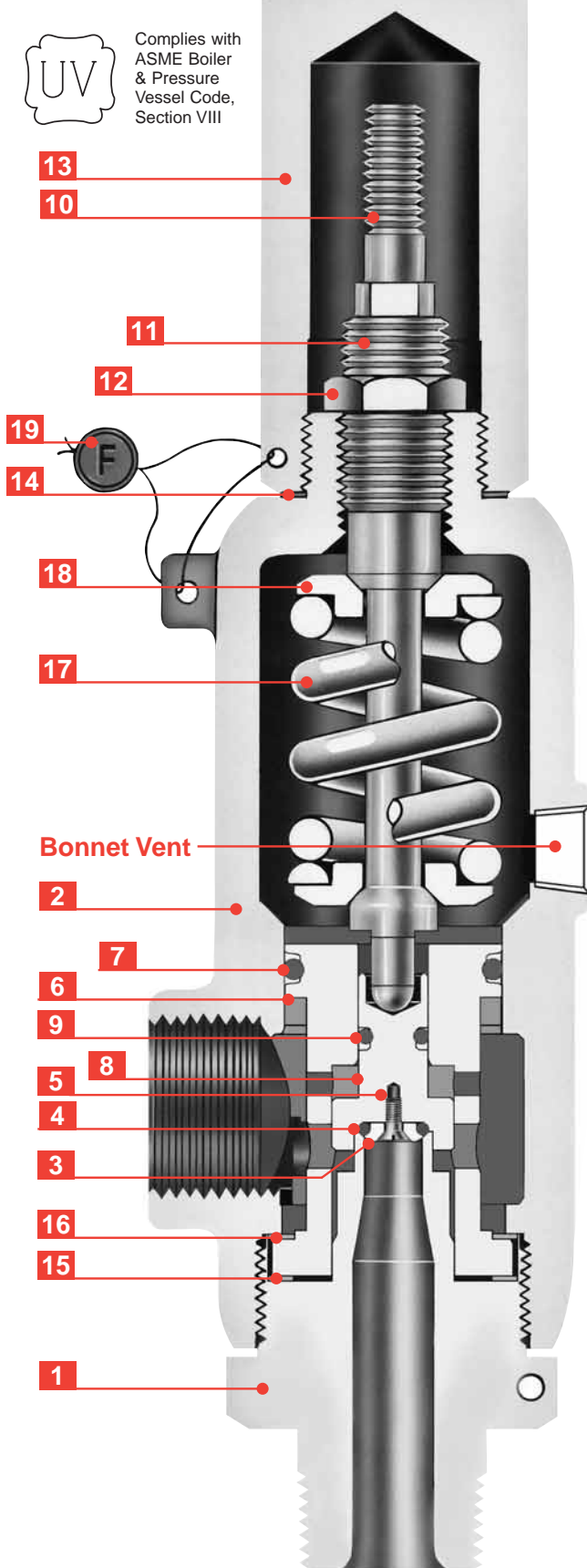

Do you have variable back pressure? Can't use a balanced bellows design? Farris has the solution with the Series 2700 balanced design pressure relief valve. The balanced effect is achieved by isolating the upper valve chamber and eliminating any back pressure build-up in the bonnet effecting valve set pressure.

These valves are available in 1/2", 3/4" and 1" inlet sizes with a 1" outlet and two orifice areas. Pressure ranges from 15 to 1480 psig, standard soft seat design. Flanged and welded inlet and outlet connections are available with the same material options as the standard design.

Item No.	Part Name	Standard Material
1	Body	SA-351, Gr. CF8M St. St. or SA-479 Type 316 St. St.
2	Bonnet	SA-216, Gr. WCB, Carb. St.
3	O-ring Retainer	316 St. St.
4	O-ring Seat Seal	Viton®
5	Retainer Lock Screw	304 St. St.
6	Guide	316 St. St.
7	Guide Seal	Viton
8	Disc Holder	316 St. St.
9	Disc Holder Seal	Viton
10	Stem	316 St. St.
11	Spring Adj. Screw	316 St. St.
12	Jam Nut	316 St. St.
13	Cap, Plain Screwed	Carbon Steel
14	Cap Gasket	316 St. St.
15	Body Gasket	316 St. St.
16	Guide Gasket	316 St. St.
17	Spring	Stainless Steel
18	Spring Buttons	316 St. St.
19	Wire Seal	St. St. Wire/Lead Seal
20	Nameplate (Not Shown)	Stainless Steel

General Notes:

1. Other O-ring materials available. Consult the Factory.
2. Flanged, socket weld, welding nipple and female threaded designs available.
3. Temperature for balanced or O-ring seat design is limited by the elastomer selected. See page 6.

Series 2700 Back Pressure Correction Factors Balanced Design

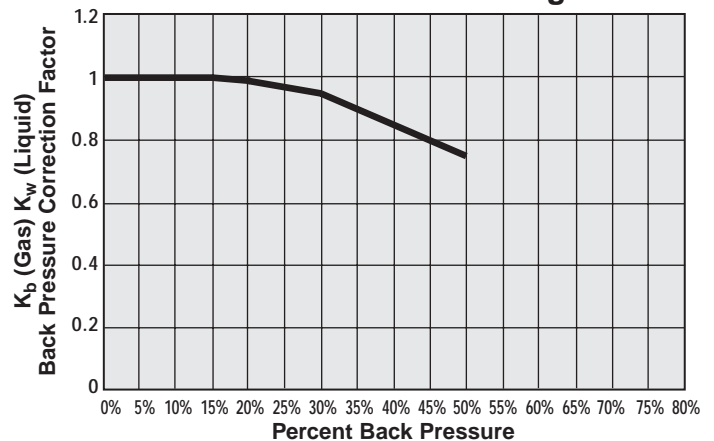

Viton is a registered trademark of DuPont Dow Elastomers.

O-ring Selection



PRESSURE & TEMPERATURE LIMITS O-RING SEAT VALVE

The 2700 Series is available with an optional O-ring seat which minimizes fugitive emissions and costly product loss. This optional seat construction provides zero bubbles per minute leakage at 90%

of set pressure per API Standard 527. The Tables below list the set pressure and temperature range for both the elastomer and Teflon seat options.

Orifice	Pressure Range, PSIG ¹		Pressure Range, Bar G ²	
	Elastomer Seat	Teflon Seat	Elastomer Seat	Teflon Seat
C High Pressure	15 to 1480 —	800 to 2500 2501 to 5000	1.00 to 102 —	55.1 to 172 172.1 to 345
D High Pressure	15 to 1480 —	800 to 1600 1601 to 5000	1.00 to 102 —	55.1 to 110 110.1 to 345
E	15 to 1480	600 to 2500	1.0 to 102	41.3 to 172
F	15 to 1480	600 to 1600	1.0 to 102	41.3 to 110
G	15 to 1000	200 to 1000	1.0 to 69	14 to 69

MATERIAL AVAILABILITY		
Material	Temperature Range ¹	
	°F	°C
Viton®	-20° to +450°	-29° to +232°
Buna N	-20° to +250°	-29° to +121°
EPR	0° to +350°	-18° to +177°
Silicone	-150° to +450°	-101° to +232°
Kalrez®	-20° to +550°	-29° to +289°
Teflon	-300° to +500°	-184° to +260°

General Notes:

1. Maximum O-ring set pressure limit cannot exceed the pressure limit for a given type number and size as indicated in the metal seat selection tables.
2. Temperature range may vary depending on service fluid.
3. Ethylene propylene is suitable for steam service up to 350°F, Teflon up to 500°F.
4. Consult the Farris Factory for other materials.

Selection Table

U.S. CUSTOMARY UNITS: THREADED CONNECTIONS-MNPT X FNPT

Orifice Area Sq. In.	Valve Size Inlet x Outlet	Type Number	Maximum Set Pressure, PSIG	Max. Back Pressure PSIG at 100°F	Materials	
			-50°F to 750°F		Body/Bonnet	Spring
0.068	1/2 x 1	27CA13-M20	1600	400	316 St. St. / Carb. St.	Stainless Steel
	3/4 x 1	27CA23-M20	2500			
	3/4 x 1	27CA23H-M20	5000			
	1 x 1	27CA33-M20	2500			
	1 x 1	27CA33H-M20	6500			
0.125	1/2 x 1	27DA13-M20	1600	400	316 St. St. / Carb. St.	Stainless Steel
	3/4 x 1	27DA23-M20	1600			
	3/4 x 1	27DA23H-M20	5000			
	1 x 1	27DA33-M20	1600			
	1 x 1	27DA33H-M20	5000			
0.223	1 x 1 1/2	27EA34-M20	2500	400	316 St. St. / Carb. St.	Stainless Steel
0.350	1 1/2 x 2	27FA45-M20	1600	400	316 St. St. / Carb. St.	Stainless Steel
0.573	1 1/2 x 2 1/2	27GA46-M20	1000	400	316 St. St. / Carb. St.	Stainless Steel

Viton and Kalrez are registered trademarks of DuPont Dow Elastomers.



Selection Tables

U.S. CUSTOMARY UNITS: FLANGED CONNECTIONS

Orifice Area Sq. In.	Valve Size Inlet x Outlet	ANSI Flange Class		Type Number	Maximum Set Pressure, PSIG			Max. Back Pressure PSIG at 100°F	Materials		
		Inlet RF	Outlet RF		-50°F to 100°F	400°F	750°F		Body / Bonnet	Spring	
0.068	1/2 x 1	150#	150#	27CA13-120	285	200	95	285	316 St. St./ Carb. St.	Stainless Steel	
		300#	150#	27CA13-220	740	635	505	285			
		600#	150#	27CA13-320	1480	1270	1010	285			
		900#	300#	27CA13-420	2220	1900	1510	400			
		1500#	300#	27CA13H-520	3705	3170	2520	400			
		2500#	300#	27CA13H-620	5000	5000	4200	400			
	3/4 x 1	150#	150#	27CA23-120	285	200	95	285	316 St. St./ Carb. St.	Stainless Steel	
		300#	150#	27CA23-220	740	635	505	285			
		600#	150#	27CA23-320	1480	1270	1010	285			
		900#	300#	27CA23-420	2220	1900	1510	400			
		1500#	300#	27CA23H-520	3705	3170	2520	400			
		2500#	300#	27CA23H-620	5000	5000	4200	400			
	1 x 1	150#	150#	27CA33-120	285	200	95	285	316 St. St./ Carb. St.	Stainless Steel	
		300#	150#	27CA33-220	740	635	505	285			
		600#	150#	27CA33-320	1480	1270	1010	285			
		900#	300#	27CA33-420	2220	1900	1510	400			
		1500#	300#	27CA33H-520	3705	3170	2520	400			
		2500#	300#	27CA33H-620	6170	5280	4200	400			
0.125	1/2 x 1	150#	150#	27DA13-120	285	200	95	285	316 St. St./ Carb. St.	Stainless Steel	
		300#	150#	27DA13-220	740	635	505	285			
		600#	150#	27DA13-320	1480	1270	1010	285			
		900#	300#	27DA13H-420	2220	1900	1510	400			
	3/4 x 1	150#	150#	27DA23-120	285	200	95	285	316 St. St./ Carb. St.	Stainless Steel	
		300#	150#	27DA23-220	740	635	505	285			
		600#	150#	27DA23-320	1480	1270	1010	285			
		900#	300#	27DA23H-420	2220	1900	1510	400			
		1500#	300#	27DA23H-520	3705	3170	2520	400			
		2500#	300#	27DA23H-620	5000	5000	4200	400			
	1 x 1	150#	150#	27DA33-120	285	200	95	285	316 St. St./ Carb. St.	Stainless Steel	
		300#	150#	27DA33-220	740	635	505	285			
		600#	150#	27DA33-320	1480	1270	1010	285			
		900#	300#	27DA33H-420	2220	1900	1510	400			
		1500#	300#	27DA33H-520	3705	3170	2520	400			
		2500#	300#	27DA33H-620	6170	5280	4200	400			
	0.223	1 x 1 1/2	150#	150#	27EA34-120	285	200	95	285	316 St. St./ Carb. St.	Stainless Steel
			300#	150#	27EA34-220	740	635	505	285		
600#			150#	27EA34-320	1480	1270	1010	285			
900#			300#	27EA34-420	2220	1900	1510	400			
0.350	1 1/2 x 2	150#	150#	27FA45-120	285	200	95	285	316 St. St./ Carb. St.	Stainless Steel	
		300#	150#	27FA45-220	740	635	505	285			
		600#	150#	27FA45-320	1480	1270	1010	285			
0.573	1 1/2 x 2 1/2	150#	150#	27GA46-120	285	200	95	285	316 St. St./ Carb. St.	Stainless Steel	
		300#	150#	27GA46-220	740	635	505	285			
		600#	150#	27GA46-320	1000	1000	1000	285			

General Notes:

- Available with optional elastomer or Teflon seat design as illustrated. Change the fourth digit of the type number from "A" to "C" for soft seat, "A" to "T" for Teflon. Example: 27DC23-M20 for soft seat, 27DT23-M20 for Teflon. See Selection Table for pressure and temperature limits.
- Above type numbers indicate standard materials of construction. To select corrosive or low temperature materials, add type number suffix as indicated on pages 3 and 9.
- Available in materials suitable for sour gas (H2S) service to NACE Standards MR0103 and MR0175 / ISO 15156. Add "N1" (standard materials) or "N4"

(all stainless construction) to the type number. Example 27DA23-M20/N1 & 27DA23-M20/N4.

- For open or packed levers, change the second digit of the type number suffix. Examples: 27FA45-M70 for open lever, 27GA46-M40 for packed lever.
- For socket weld or welding nipple connections, change the first digit of the type number suffix to "S" for socket weld or "W" for welding nipple inlet and outlet. Examples: 27DA33-S20 for socket weld, 27DA33-W20 for welding nipple.
- Female threaded inlet available. Change first digit of type number suffix to "F". Example: 27EA-34-F20.
- For set pressures below 15 psig, consult the Farris Factory.

Selection Tables - Balanced Design



U.S. CUSTOMARY UNITS: THREADED CONNECTIONS-MNPT X FNPT

Orifice Area Sq. In.	Valve Size Inlet x Outlet	Type Number	Maximum Set Pressure, PSIG	Max. Back Pressure PSIG at 100°F	Materials	
			-20°F to 450°F		Body/Bonnet	Spring
0.068	1/2 x 1	27CC13B-M20	1480	400	316 St. St. / Carb. St.	Stainless Steel
	3/4 x 1	27CC23B-M20				
	1 x 1	27CC33B-M20				
0.125	1/2 x 1	27DC13B-M20	1480	400	316 St. St. / Carb. St.	Stainless Steel
	3/4 x 1	27DC23B-M20				
	1 x 1	27DC33B-M20				

U.S. CUSTOMARY UNITS: FLANGED CONNECTIONS

Orifice Area Sq. In.	Valve Size Inlet x Outlet	ANSI Flange Class		Type Number	Maximum Set Pressure, PSIG		Max. Back Pressure PSIG at 100°F	Materials	
		Inlet RF	Outlet RF		-20°F to 100°F	400°F		Body / Bonnet	Spring
0.068	1/2 x 1	150#	150#	27CC13B-120	285	200	285	316 St. St./ Carb. St.	Stainless Steel
		300#	150#	27CC13B-220	740	635	285		
		600#	150#	27CC13B-320	1480	1270	285		
		900#	300#	27CC13B-420	1480	1270	400		
	3/4 x 1	150#	150#	27CC23B-120	285	200	285	316 St. St./ Carb. St.	Stainless Steel
		300#	150#	27CC23B-220	740	635	285		
		600#	150#	27CC23B-320	1480	1270	285		
		900#	300#	27CC23B-420	1480	1270	400		
	1 x 1	150#	150#	27CC33B-120	285	200	285	316 St. St./ Carb. St.	Stainless Steel
		300#	150#	27CC33B-220	740	635	285		
		600#	150#	27CC33B-320	1480	1270	285		
		900#	300#	27CC33B-420	1480	1270	400		
0.125	1/2 x 1	150#	150#	27DC13B-120	285	200	285	316 St. St./ Carb. St.	Stainless Steel
		300#	150#	27DC13B-220	740	635	285		
		600#	150#	27DC13B-320	1480	1270	285		
	3/4 x 1	150#	150#	27DC23B-120	285	200	285	316 St. St./ Carb. St.	Stainless Steel
		300#	150#	27DC23B-220	740	635	285		
		600#	150#	27DC23B-320	1480	1270	285		
	1 x 1	150#	150#	27DC33B-120	285	200	285	316 St. St./ Carb. St.	Stainless Steel
		300#	150#	27DC33B-220	740	635	285		
		600#	150#	27DC33B-320	1480	1270	285		



Part Name	316 St. St.		Monel			Hastelloy C		
	N1 (NACE)	S4 & N4	M1	M2	M4	H1	H2	H4
	-50°F to 750°F	-450°F to 750°F ²	-50°F to 600°F		-325°F to 600°F	-50°F to 500°F		-325°F to 500°F
Body	—	—	Monel	Monel	Monel	Hastelloy C	Hastelloy C	Hastelloy C
Bonnet	—	SA-351 Gr. CF8M St. St.	—	—	Monel	—	—	Hastelloy C
Disc	—	—	Monel	Monel	Monel	Hastelloy C	Hastelloy C	Hastelloy C
Guide	—	—	—	Monel	Monel	—	Hastelloy C	Hastelloy C
Disc Holder	—	—	—	Monel	Monel	—	Hastelloy C	Hastelloy C
Stem	—	—	—	—	Monel	—	—	Hastelloy C
Spring Adj. Screw	—	—	—	—	Monel	—	—	Hastelloy C
Jam Nut	—	—	—	—	Monel	—	—	Hastelloy C
Cap, Plain Screwed	—	316 St. St.	—	—	Monel	—	—	Hastelloy C
Cap Gasket	—	—	—	—	Monel	—	—	Hastelloy C
Body Gasket	—	—	—	Monel	Monel	—	Hastelloy C	Hastelloy C
Guide Gasket	—	—	—	Monel	Monel	—	Hastelloy C	Hastelloy C
Spring	Inconel® X-750	316 St. St./ Inconel x-750	—	Inconel X-750	Inconel X-750	—	Inconel X-750	Hastelloy C
Spring Buttons	—	—	—	—	Monel	—	—	Hastelloy C
O-Ring Retainer (note 5)	—	316 St. St.	Monel	Monel	Monel	Hastelloy C	Hastelloy C	Hastelloy C
Retainer Lock Screw (note 5)	—	316 St. St.	Monel	Monel	Monel	Hastelloy C	Hastelloy C	Hastelloy C
O-Ring Seat Seal (note 5)	—	—	—	—	—	—	—	—
Guide Seal (note 5)	—	—	—	—	—	—	—	—
Disc Holder Seal (note 5)	—	—	—	—	—	—	—	—
Wire Seal	—	—	—	—	—	—	—	—
Nameplate (Not Shown)	—	—	—	—	—	—	—	—
Welding Nipple (Inlet)	—	—	Monel	Monel	Monel	Hastelloy C	Hastelloy C	Hastelloy C
Welding Nipple (Outlet)	—	316 St. St.	—	—	Monel	—	—	Hastelloy C
Lap Joint Stub End (Inlet)	—	—	Monel	Monel	Monel	Hastelloy C	Hastelloy C	Hastelloy C
Lap Joint Stub End (Outlet)	—	316 St.St.	—	—	Monel	—	—	Hastelloy C
Lap Joint Flange (Inlet)(note 4)	—	316 St. St.	—	—	Monel	—	—	Hastelloy C
Lap Joint Flange (Outlet)(note 4)	—	316 St. St.	—	—	Monel	—	—	Hastelloy C

General Notes:

1. Any part denoted with a dash is standard material.
2. For S4 trim, a 17-4 Ph. or 17-7 Ph. spring may be necessary for some pressures and temperatures.
3. For open and packed lever materials, see page 16.
4. Maximum set pressures for S4, M4, and H4 trim are the same as the carbon steel valves or the 316 St. St., Monel and Hastelloy C flange limits respectively, whichever is lower.
5. Temperature for balanced or O-ring seat design is limited by the elastomer selected. For Viton O-rings, the temperature range is -20°F to +450°F. For other materials, consult chart on page 6.
6. Hastelloy and Hastelloy C are registered trademarks of Haynes International. Monel, Inconel and Inconel X-750 are registered trademarks of Inco Alloys International. We reserve the right to substitute comparable material from other manufacturers.

AIR

10% OVERPRESSURE
Capacities in Standard Cubic Feet Per Minute at 60°F

Set Pressure (PSIG)	Orifice Area, Sq. In.				
	C	D	E	F	G
	0.068	0.125	0.223	0.350	0.573
15	35	65	117	183	301
20	41	75	135	212	347
30	52	95	171	268	439
40	64	117	210	330	540
50	76	140	249	392	642
60	88	162	288	454	743
70	100	184	328	515	844
80	112	206	368	577	946
90	124	228	407	639	1047
100	136	250	447	701	1148
150	196	361	644	1011	1655
200	256	471	841	1320	2161
250	316	582	1038	1630	2668
300	376	692	1235	1939	3175
350	436	803	1432	2248	3681
400	497	913	1630	2558	4188
450	557	1024	1827	2867	4695
500	617	1134	2024	3177	5201
550	677	1245	2221	3486	5708
600	737	1355	2418	3796	6215
650	797	1466	2615	4105	6721
700	857	1576	2813	4415	7228
750	917	1687	3010	4724	7735
800	978	1797	3207	5034	8241
850	1038	1908	3404	5343	8748
900	1098	2018	3601	5653	9255
950	1158	2129	3799	5962	9761
1000	1218	2240	3996	6272	10268
1050	1278	2350	4193	6581	---
1100	1338	2461	4390	6891	---
1150	1398	2571	4587	7200	---
1200	1459	2682	4784	7509	---
1250	1519	2792	4982	7819	---
1300	1579	2903	5179	8128	---
1350	1639	3013	5376	8438	---
1400	1699	3124	5573	8747	---
1450	1759	3234	5770	9057	---
1500	1819	3345	5967	9366	---
1550	1879	3455	6165	9676	---
1600	1940	3566	6362	9985	---
1650	2000	3676	6559	---	---
1700	2060	3787	6756	---	---
1750	2120	3897	6953	---	---
1800	2180	4008	7151	---	---
1850	2240	4118	7348	---	---
1900	2300	4229	7545	---	---
2000	2421	4450	7939	---	---
2100	2541	4671	8334	---	---
2200	2661	4892	8728	---	---
2300	2781	5113	9122	---	---
2400	2902	5334	9577	---	---
2500	3022	5555	9911	---	---
2600	3142	5776	---	---	---
2700	3262	5997	---	---	---
2800	3383	6218	---	---	---
2900	3503	6439	---	---	---
3000	3623	6661	---	---	---
3500	4224	7766	---	---	---
4000	4826	8871	---	---	---
4500	5427	9976	---	---	---
5000	6028	11081	---	---	---
5500	6629	---	---	---	---
6000	7231	---	---	---	---
6500	7832	---	---	---	---

Capacity Tables



U.S. CUSTOMARY UNITS:
ASME PRESSURE VESSEL CODE, SECTION VIII
(UV) STAMP

STEAM

10% OVERPRESSURE
Capacities in Pounds Per Hour at Saturation Temperature

Set Pressure (PSIG)	Orifice Area, Sq. In.				
	C	D	E	F	G
	0.068	0.125	0.223	0.350	0.573
15	100	184	329	516	846
20	115	212	379	595	975
30	146	269	480	754	1234
40	180	331	591	927	1519
50	214	393	702	1101	1803
60	247	455	812	1275	2088
70	281	517	923	1449	2373
80	315	579	1034	1623	2657
90	349	641	1145	1797	2942
100	382	704	1255	1971	3227
150	551	1014	1809	2840	4650
200	720	1325	2363	3710	6073
250	889	1635	2917	4579	7497
300	1058	1946	3471	5448	8920
350	1227	2256	4025	6318	10344
400	1396	2567	4579	7187	11767
450	1565	2877	5133	8057	13190
500	1734	3188	5687	8926	14614
550	1903	3498	6241	9796	16037
600	2072	3809	6795	10665	17461
650	2241	4119	7349	11535	18884
700	2410	4430	7903	12404	20307
750	2578	4740	8457	13273	21731
800	2747	5051	9011	14143	23154
850	2916	5361	9565	15012	24578
900	3085	5672	10119	15882	26001
950	3254	5982	10673	16751	27424
1000	3423	6293	11227	17621	28848
1050	3592	6603	11781	18490	---
1100	3761	6914	12335	19359	---

General Notes:

1. Capacities at 30 PSIG and below are based on 3 PSI overpressure.
2. For sizing purposes, the coefficients of discharge K are 0.878 for air, gas & steam; 0.676 for liquids.

Farris Capacity Tables

U.S. CUSTOMARY UNITS:
ASME PRESSURE VESSEL CODE,
SECTION VIII (UV) STAMP

WATER					
10% OVERPRESSURE Capacities in U.S. Gallons Per Minute at 70°F ³					
Set Pressure (PSIG)	Orifice Area, Sq. In.				
	C	D	E	F	G
	0.068	0.125	0.223	0.350	0.573
15	7.4	13.6	24.3	38.1	62.4
20	8.3	15.3	27.4	43.1	70.5
30	10.0	18.4	32.9	51.6	84.5
40	11.5	21.2	37.9	59.6	97.6
50	12.9	23.8	42.4	66.6	109
60	14.1	26.0	46.5	73.0	119
70	15.3	28.1	50.2	78.8	129
80	16.3	30.1	53.7	84.3	138
90	17.3	31.9	56.9	89.4	146
100	18.3	33.6	60.0	94.2	154
150	22.4	41.2	73.5	115	189
200	25.9	47.6	84.9	133	218
250	28.9	53.2	94.9	149	244
300	31.7	58.3	104	163	267
350	34.2	63.0	112	176	288
400	36.6	67.3	120	188	308
450	38.8	71.4	127	200	327
500	40.9	75.3	134	210	345
550	42.9	78.9	140	221	362
600	44.8	82.4	147	230	378
650	46.7	85.8	153	240	393
700	48.4	89.0	158	249	408
750	50.1	92.2	164	258	422
800	51.8	95.2	169	266	436
850	53.4	98.1	175	274	450
900	54.9	101	180	282	463
950	56.4	103	185	290	475
1000	57.9	106	189	298	488
1050	59.3	109	194	305	---
1100	60.7	111	199	312	---
1150	62.1	114	203	319	---
1200	63.4	116	208	326	---
1250	64.7	119	212	333	---
1300	66.0	121	216	339	---
1350	67.3	123	220	346	---
1400	68.5	126	224	352	---
1450	69.7	128	228	359	---
1500	70.9	130	232	365	---
1550	72.1	132	236	371	---
1600	73.2	134	240	377	---
1650	74.4	136	244	---	---
1700	75.5	138	247	---	---
1750	76.6	140	251	---	---
1800	77.7	142	254	---	---
1850	78.7	144	258	---	---
1900	79.8	146	261	---	---
2000	81.9	150	268	---	---
2100	83.9	154	275	---	---
2200	85.9	157	281	---	---
2300	87.8	161	288	---	---
2400	89.7	164	294	---	---
2500	91.5	168	300	---	---
2600	93.4	171	---	---	---
2700	95.1	174	---	---	---
2800	96.9	178	---	---	---
2900	98.6	181	---	---	---
3000	100	184	---	---	---
3500	108	199	---	---	---
4000	115	212	---	---	---
4500	122	225	---	---	---
5000	129	238	---	---	---
5500	135	---	---	---	---
6000	141	---	---	---	---
6500	147	---	---	---	---

General Notes:

1. Capacities at 30 PSIG and below are based on 3 PSI overpressure.
2. For sizing purposes, the coefficients of discharge K are 0.878 for air, gas & steam; 0.676 for liquids.
3. To determine capacity at 25% overpressure, multiply the capacity at 10% by 1.066.

Selection Tables - Metric - Conventional



THREADED CONNECTIONS-MNPT X FNPT

Orifice Area Sq. mm	Valve Size Inlet x Outlet	Type Number	Maximum Set Pressure, Bar G	Max. Back Pressure Bar G at 37.8°C	Materials	
			-45.6°C to 399°C		Body / Bonnet	Spring
43.87	1/2 x 1	27CA13-M20	110	28	316 St. St. / Carb. St.	Stainless Steel
	3/4 x 1	27CA23-M20	172			
	3/4 x 1	27CA23H-M20	345			
	1 x 1	27CA33-M20	172			
	1 x 1	27CA33H-M20	448			
80.65	1/2 x 1	27DA13-M20	110	28	316 St. St. / Carb. St.	Stainless Steel
	3/4 x 1	27DA23-M20	110			
	3/4 x 1	27DA23H-M20	345			
	1 x 1	27DA33-M20	110			
	1 x 1	27DA33H-M20	345			
143.87	1 x 1 1/2	27EA34-M20	172	28	316 St. St. / Carb. St.	Stainless Steel
225.81	1 1/2 x 2	27FA45-M20	110	28	316 St. St. / Carb. St.	Stainless Steel
369.68	1 1/2 x 2 1/2	27GA46-M20	69	28	316 St. St. / Carb. St.	Stainless Steel

General Notes:

- Available with optional elastomer or Teflon seat design as illustrated. Change the fourth digit of the type number from "A" to "C" for soft seat, "A" to "T" for Teflon. Examples: 27DC23-M20 for soft seat, 27DT23-M20 for Teflon. For O-ring pressure and temperature limits, see selection table on page 6.
- Above type numbers indicate the standard materials of construction. To select corrosive or low temperature materials, add type number suffix as indicated on pages 3 and 5. Example: 27FA45-M20/S4.
- Available in materials suitable for sour gas (H₂S) service to NACE Standards MR0103 and MR0175 / ISO 15156. Add "N1" (standard materials) or "N4" (all stainless construction) to the type number. Example 27DA23-M20/N1 & 27DA23-M20/N4.
- For open or packed levers, change the second digit of the type number suffix. Examples: 27FA45-M70 for open lever, 27GA46-M40 for packed lever.
- For socket weld or welding nipple connections, change the first digit of the type number suffix to "S" for socket weld or "W" for welding nipple inlet and outlet. Examples: 27DA33-S20 for socket weld, 27DA33-W20 for welding nipple.



Selection Tables - Metric - Conventional

FLANGED CONNECTIONS

Orifice Area Sq. mm	Valve Size Inlet x Outlet	ANSI Flange Class		Type Number	Maximum Set Pressure, Bar G			Max. Back Pressure Bar G at 37.8°C	Materials		
		Inlet RF	Outlet RF		-45.6°C to 37.8°C	204°C	399°C		Body / Bonnet	Spring	
43.87	1/2 x 1	150#	150#	27CA13-120	20	14	6	20	316 St. St./ Carb. St.	Stainless Steel	
		300#	150#	27CA13-220	51	44	35	20			
		600#	150#	27CA13-320	102	88	69	20			
		900#	300#	27CA13-420	153	131	104	28			
		1500#	300#	27CA13H-520	255	218	174	28			
		2500#	300#	27CA13H-620	345	345	290	28			
	3/4 x 1	150#	150#	27CA23-120	20	14	6	20	316 St. St./ Carb. St.	Stainless Steel	
		300#	150#	27CA23-220	51	44	35	20			
		600#	150#	27CA23-320	102	88	69	20			
		900#	300#	27CA23-420	153	131	104	28			
		1500#	300#	27CA23H-520	255	218	174	28			
		2500#	300#	27CA23H-620	345	345	290	28			
	1 x 1	150#	150#	27CA33-120	20	14	6	20	316 St. St./ Carb. St.	Stainless Steel	
		300#	150#	27CA33-220	51	44	35	20			
		600#	150#	27CA33-320	102	88	69	20			
		900#	300#	27CA33-420	153	131	104	28			
		1500#	300#	27CA33H-520	255	218	174	28			
		2500#	300#	27CA33H-620	425	364	290	28			
80.65	1/2 x 1	150#	150#	27DA13-120	20	14	6	20	316 St. St./ Carb. St.	Stainless Steel	
		300#	150#	27DA13-220	51	44	35	20			
		600#	150#	27DA13-320	102	88	69	20			
		900#	300#	27DA13H-420	153	131	104	28			
	3/4 x 1	150#	150#	27DA23-120	20	14	6	20	316 St. St./ Carb. St.	Stainless Steel	
		300#	150#	27DA23-220	51	44	35	20			
		600#	150#	27DA23-320	102	88	69	20			
		900#	300#	27DA23H-420	153	131	104	28			
		1500#	300#	27DA23H-520	255	218	174	28			
		2500#	300#	27DA23H-620	345	345	290	28			
	1 x 1	150#	150#	27DA33-120	20	14	6	20	316 St. St./ Carb. St.	Stainless Steel	
		300#	150#	27DA33-220	51	44	35	20			
		600#	150#	27DA33-320	102	88	69	20			
		900#	300#	27DA33H-420	153	131	104	28			
		1500#	300#	27DA33H-520	255	218	174	28			
		2500#	300#	27DA33H-620	425	364	290	28			
	143.87	1 x 1 1/2	150#	150#	27EA34-120	20	14	6	20	316 St. St./ Carb. St.	Stainless Steel
			300#	150#	27EA34-220	51	44	35	20		
600#			150#	27EA34-320	102	88	69	20			
900#			300#	27EA34-420	153	131	104	28			
225.81	1 1/2 x 2	150#	150#	27FA45-120	20	14	6	20	316 St. St./ Carb. St.	Stainless Steel	
		300#	150#	27FA45-220	51	44	35	20			
		600#	150#	27FA45-320	102	88	69	20			
369.68	1 1/2 x 2 1/2	150#	150#	27GA46-120	20	14	6	20	316 St. St./ Carb. St.	Stainless Steel	
		300#	150#	27GA46-220	51	44	35	20			
		600#	150#	27GA46-320	69	69	69	20			

Selection Tables - Metric - Balanced Design



THREADED CONNECTIONS - MNPT X FNPT

Orifice Area Sq. mm	Valve Size Inlet x Outlet	Type Number	Maximum Set Pressure, Bar G	Max. Back Pressure Bar G at 37.8°C	Materials	
			-28.9°C to 232°C		Body / Bonnet	Spring
43.87	1/2 x 1	27CC13B-M20	102	28	316 St. St. / Carb. St.	Stainless Steel
	3/4 x 1	27CC23B-M20				
	1 x 1	27CC33B-M20				
80.65	1/2 x 1	27DC13B-M20	102	28	316 St. St. / Carb. St.	Stainless Steel
	3/4 x 1	27DC23B-M20				
	1 x 1	27DC33B-M20				

FLANGED CONNECTIONS

Orifice Area Sq. mm	Valve Size Inlet x Outlet	ANSI Flange Class		Type Number	Maximum Set Pressure, Bar G		Max. Back Pressure Bar G at 37.8°C	Materials	
		Inlet RF	Outlet RF		-28.9°C to 37.8°C	204°C		Body / Bonnet	Spring
43.87	1/2 x 1	150#	150#	27CC13B-120	20	14	20	316 St. St./ Carb. St.	Stainless Steel
		300#	150#	27CC13B-220	51	44	20		
		600#	150#	27CC13B-320	102	88	20		
		900#	300#	27CC13B-420	102	88	28		
	3/4 x 1	150#	150#	27CC23B-120	20	14	20	316 St. St./ Carb. St.	Stainless Steel
		300#	150#	27CC23B-220	51	44	20		
		600#	150#	27CC23B-320	102	88	20		
		900#	300#	27CC23B-420	102	88	28		
	1 x 1	150#	150#	27CC33B-120	20	14	20	316 St. St./ Carb. St.	Stainless Steel
		300#	150#	27CC33B-220	51	44	20		
		600#	150#	27CC33B-320	102	88	20		
		900#	300#	27CC33B-420	102	88	28		
80.65	1/2 x 1	150#	150#	27DC13B-120	20	14	20	316 St. St./ Carb. St.	Stainless Steel
		300#	150#	27DC13B-220	51	44	20		
		600#	150#	27DC13B-320	102	88	20		
	3/4 x 1	150#	150#	27DC23B-120	20	14	20	316 St. St./ Carb. St.	Stainless Steel
		300#	150#	27DC23B-220	51	44	20		
		600#	150#	27DC23B-320	102	88	20		
	1 x 1	150#	150#	27DC33B-120	20	14	20	316 St. St./ Carb. St.	Stainless Steel
		300#	150#	27DC33B-220	51	44	20		
		600#	150#	27DC33B-320	102	88	20		



Capacity Tables - Metric Units

ASME PRESSURE VESSEL CODE, SECTION VIII (UV) STAMP

AIR					
10% OVERPRESSURE					
Capacities in Standard Cubic Meters Per Minute at 15.6°C					
Set Pressure (BarG)	Orifice Area, Sq. mm.				
	C	D	E	F	G
	43.87	80.65	143.87	225.81	369.68
1	1.0	1.8	3.3	5.1	8.4
2	1.4	2.7	4.7	7.4	12.2
3	1.9	3.6	6.3	10.0	16.3
4	2.4	4.5	8.0	12.5	20.5
5	2.9	5.4	9.6	15.1	24.6
6	3.4	6.3	11.2	17.6	28.8
7	3.9	7.2	12.8	20.1	33.0
8	4.4	8.1	14.5	22.7	37.1
9	4.9	9.0	16.1	25.2	41.3
10	5.4	9.9	17.7	27.8	45.5
12	6.4	11.7	20.9	32.8	53.8
14	7.4	13.5	24.2	37.9	62.1
16	8.4	15.4	27.4	43.0	70.4
18	9.3	17.2	30.6	48.1	78.8
20	10.3	19.0	33.9	53.2	87.1
25	12.8	23.5	42.0	65.9	107.9
30	15.3	28.1	50.1	78.6	128.7
35	17.7	32.6	58.2	91.3	149.5
40	20.2	37.2	66.3	104.0	170.3
45	22.7	41.7	74.4	116.7	191.1
50	25.1	46.2	82.5	129.5	211.9
55	27.6	50.8	90.6	142.2	232.7
60	30.1	55.3	98.7	154.9	253.6
65	32.5	59.9	106.8	167.6	274.4
70	35.0	64.4	114.9	180.3	295.2
75	37.5	68.9	123.0	193.0	---
80	40.0	73.5	131.1	205.7	---
85	42.4	78.0	139.2	218.4	---
90	44.9	82.5	147.3	231.1	---
95	47.4	87.1	155.4	243.9	---
100	49.8	91.6	163.5	256.6	---
105	52.3	96.2	171.6	269.3	---
110	54.8	100.7	179.7	282.0	---
115	57.2	105.2	187.8	---	---
120	59.7	109.8	195.9	---	---
125	62.2	114.3	204.0	---	---
130	64.7	118.9	212.1	---	---
135	67.1	123.4	220.2	---	---
140	69.6	127.9	228.3	---	---
145	72.1	132.5	236.4	---	---
150	74.5	137.0	244.5	---	---
155	77.0	141.6	252.6	---	---
160	79.5	146.1	260.7	---	---
165	81.9	150.6	268.8	---	---
170	84.4	155.2	276.9	---	---
175	86.9	159.7	---	---	---
180	89.3	164.3	---	---	---
185	91.8	168.8	---	---	---
190	94.3	173.3	---	---	---
195	96.8	177.9	---	---	---
200	99.2	182.4	---	---	---
220	109.1	200.6	---	---	---
240	119.0	218.7	---	---	---
260	128.9	236.9	---	---	---
280	138.7	255.1	---	---	---
300	148.6	273.2	---	---	---
320	158.5	291.4	---	---	---
340	168.4	309.5	---	---	---
360	178.2	---	---	---	---
380	188.1	---	---	---	---
400	198.0	---	---	---	---
420	207.9	---	---	---	---
440	217.8	---	---	---	---
448	221.7	---	---	---	---

WATER					
10% OVERPRESSURE					
Capacities in Litres Per Minutes at 21°C ³					
Set Pressure (BarG)	Orifice Area, Sq. mm.				
	C	D	E	F	G
	43.87	80.65	143.87	225.81	369.68
1	27.6	50.8	90.7	142	233
2	37.4	68.7	122	192	315
3	45.7	84.0	150	235	385
4	52.8	97.0	173	271	445
5	59.0	108	193	303	497
6	64.6	118	212	332	545
7	69.8	128	229	359	588
8	74.6	137	244	384	629
9	79.2	145	259	407	667
10	83.5	153	273	429	703
12	91.4	168	300	470	770
14	98.8	181	324	508	832
16	105	194	346	543	890
18	112	205	367	576	944
20	118	217	387	607	995
25	132	242	433	679	1112
30	144	265	474	744	1218
35	156	287	512	804	1316
40	167	307	547	859	1407
45	177	325	580	911	1492
50	186	343	612	961	1573
55	195	360	642	1008	1650
60	204	376	670	1052	1723
65	212	391	698	1095	1794
70	220	406	724	1137	1861
75	228	420	750	1177	---
80	236	434	774	1215	---
85	243	447	798	1253	---
90	250	460	821	1289	---
95	257	473	844	1324	---
100	264	485	866	1359	---
105	270	497	887	1392	---
110	276	509	908	1425	---
115	283	520	928	---	---
120	289	531	948	---	---
125	295	542	968	---	---
130	301	553	987	---	---
135	306	564	1006	---	---
140	312	574	1024	---	---
145	318	584	1042	---	---
150	323	594	1060	---	---
155	328	604	1078	---	---
160	334	614	1095	---	---
165	339	623	1112	---	---
170	344	632	1129	---	---
175	349	642	---	---	---
180	354	651	---	---	---
185	359	660	---	---	---
190	364	669	---	---	---
195	368	677	---	---	---
200	373	686	---	---	---
220	391	720	---	---	---
240	409	752	---	---	---
260	425	782	---	---	---
280	441	812	---	---	---
300	457	840	---	---	---
320	472	868	---	---	---
340	486	895	---	---	---
360	501	---	---	---	---
380	514	---	---	---	---
400	528	---	---	---	---
420	541	---	---	---	---
440	553	---	---	---	---
448	558	---	---	---	---

General Notes:

1. Capacities at 2.0 BarG set pressure and below are based on 0.2 Bar overpressure.
2. For sizing purposes, the coefficients of discharge K are 0.878 for air, gas & steam; 0.676 for liquids.
3. To determine water capacity at 25% overpressure, multiply the capacity at 10% by 1.066.

Capacity Tables - Metric Units



ASME PRESSURE VESSEL CODE, SECTION VIII (UV) STAMP

STEAM					
10% OVERPRESSURE					
Capacities in Kilograms Per Hour at Saturation Temperature					
Set Pressure (BarG)	Orifice Area, Sq. mm.				
	C	D	E	F	G
	43.87	80.65	143.87	225.81	369.68
1	44	82	147	231	378
2	65	119	213	335	548
3	87	160	286	448	734
4	109	201	358	563	921
5	132	242	431	677	1109
6	154	283	504	792	1296
7	176	323	577	906	1483
8	198	364	650	1020	1671
9	220	405	723	1135	1858
10	243	446	796	1249	2045
12	287	528	942	1478	2420
14	332	610	1087	1707	2794
16	376	691	1233	1936	3169
18	420	773	1379	2165	3544
20	465	855	1525	2393	3918
25	576	1059	1889	2965	4854
30	687	1263	2253	3537	5791
35	798	1467	2618	4109	6727
40	909	1672	2982	4681	7664
45	1021	1876	3347	5253	8600
50	1132	2080	3711	5825	9537
55	1243	2284	4076	6397	10473
60	1354	2489	4440	6969	11409
65	1465	2693	4805	7541	12346
70	1576	2898	5169	8113	13282
75	1687	3102	5533	8685	14219

General Notes:

1. Capacities at 2.0 BarG set pressure and below are based on 0.2 Bar overpressure.
2. For sizing purposes, the coefficients of discharge K are 0.878 for air, gas & steam; 0.676 for liquids.

Cap Constructions

Cap Construction	Item No.	Part Name	Standard Materials	316 St. St.		Monel		Hastelloy C	
				S4 & N4	N1	M1 & M2	M4	H1 & H2	H4
M70 Open Lever	1	Test Lever	Iron	---	---	---	---	---	---
	2	Cap, O.L.	Iron	---	---	---	---	---	---
	3	Stem Test Washer	St. St.	316 St. St.	---	---	Monel	---	Hast. C
	4	Stem Jam Nut	St. St.	316 St. St.	---	---	Monel	---	Hast. C
	5	Button Head Rivet	Steel	---	---	---	---	---	---
	6	Set Screw	Steel	---	---	---	---	---	---
M40 Packed Lever	7	Test Lever	Steel	---	---	---	---	---	---
	8	Cap, Packed	Steel	316 St. St.	---	---	Monel	---	Hast. C
	9	Stem Test Washer	St. St.	316 St. St.	---	---	Monel	---	Hast. C
	10	Stem Jam Nut	St. St.	316 St. St.	---	---	Monel	---	Hast. C
	11	Cam	St. St.	316 St. St.	---	---	Monel	---	Hast. C
	12	Gland	St. St.	316 St. St.	---	---	Monel	---	Hast. C
	13	Gland Nut	St. St.	316 St. St.	---	---	Monel	---	Hast. C
	14	Packing Ring	Graphite	---	---	---	---	---	---
	15	Gland Nut Gasket	Flexible Graphite	PTFE, Filled	PTFE, Filled	---	PTFE, Filled	---	PTFE, Filled
	16	Groove Pin	Steel Plt'd	---	---	---	---	---	---

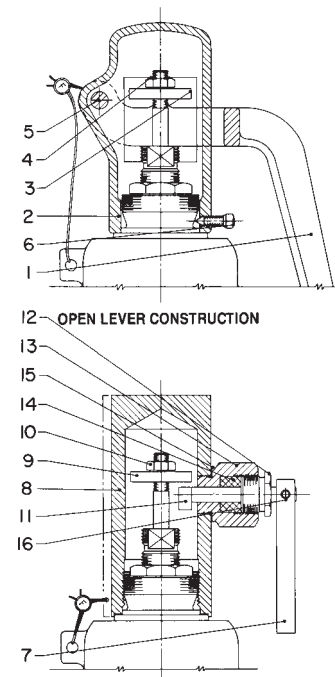

General Notes:

1. Any part denoted with a dash is standard material.
2. "S4" trim suitable for cryogenic service.



THREADED CONNECTIONS (MNPT X FNPT)								
Valve Size	US Customary Units (Inches)			Metric Units (millimeters)			Approximate Weight	
Inlet x Outlet	A Max. All Cap Const.	B	C	A Max. All Cap Const.	B	C	Lbs.	Kgs.
C and D Orifice								
1/2 x 1	11 1/4	1 3/4	3 9/16	282	45	91	8	3.6
3/4 x 1	11 1/4	1 3/4	3 9/16	286	45	91	8	3.6
3/4 x 1 H.P.	13 5/8	2 1/2	3 3/4	346	64	95	14	6.3
1 x 1	11 1/2	1 3/4	3 3/4	292	45	95	8	3.6
1 x 1 H.P.	13 5/8	1 1/2	3 3/4	346	64	95	14	6.3
E Orifice								
1 x 1 1/2	13 5/8	2 1/2	3 1/2	346	64	89	16	7.2
F Orifice								
1 1/2 x 2	14 9/16	3	3 7/8	370	76	98	17	7.7
G Orifice								
1 1/2 x 2 1/2	14 9/16	3	4 1/8	370	76	105	18	8.1

WELDING NIPPLE CONNECTIONS								
Valve Size	US Customary Units (Inches)			Metric Units (millimeters)			Approximate Weight	
Inlet x Outlet	A Max. All Cap Const.	B	C	A Max. All Cap Const.	B	C	Lbs.	Kgs.
C and D Orifice								
1/2 x 1	13	3 3/16	5 1/4	330	81	133	9	4
1/2 x 1 H.P.	15 3/16	3 15/16	5 5/16	386	100	135	15	6.8
3/4 x 1	12 15/16	3 3/16	5 3/16	329	81	132	9	4
3/4 x 1 H.P.	15 1/8	3 15/16	5 1/4	384	100	133	15	6.8
1 x 1	12 7/8	3 3/16	5 1/8	327	81	130	9	4
1 x 1 H.P.	15 1/16	3 15/16	5 3/16	383	100	132	15	6.8
E Orifice								
1 x 1 1/2	14 13/16	3 13/16	4 15/16	376	97	125	17	7.7
F Orifice								
1 1/2 x 2	15 7/8	5 3/16	5 3/16	403	132	132	18	8.1
G Orifice								
1 1/2 x 2 1/2	15 7/8	5 3/16	5 7/16	403	132	128	19	8.6

SOCKET WELD & FNPT X FNPT CONNECTIONS								
Valve Size	US Customary Units (Inches)			Metric Units (millimeters)			Approximate Weight	
Inlet x Outlet	A Max. All Cap Const.	B	C	A Max. All Cap Const.	B	C	Lbs.	Kgs.
C and D Orifice								
1/2 x 1	11 7/16	1 3/4	3 11/16	291	45	94	8	3.6
1/2 x 1 H.P.	13 5/8	2 1/2	3 3/4	346	64	95	14	6.3
3/4 x 1	11 7/16	1 3/4	3 11/16	291	45	94	8	3.6
3/4 x 1 H.P.	13 5/8	2 1/2	3 3/4	346	64	95	14	6.3
1 x 1	11 7/16	1 3/4	3 11/16	291	45	94	8	3.6
1 x 1 H.P.	13 5/8	2 1/2	3 3/4	346	64	95	14	6.3
E Orifice								
1 x 1 1/2	13 3/8	2 1/2	3 1/2	340	64	89	16	7.2
F Orifice								
1 1/2 x 2	14 9/16	3	3 7/8	370	76	98	17	7.7
G Orifice								
1 1/2 x 2 1/2	14 9/16	3	4 1/8	370	76	105	18	8.1

Note: H.P. designates the high pressure version of a given inlet size.

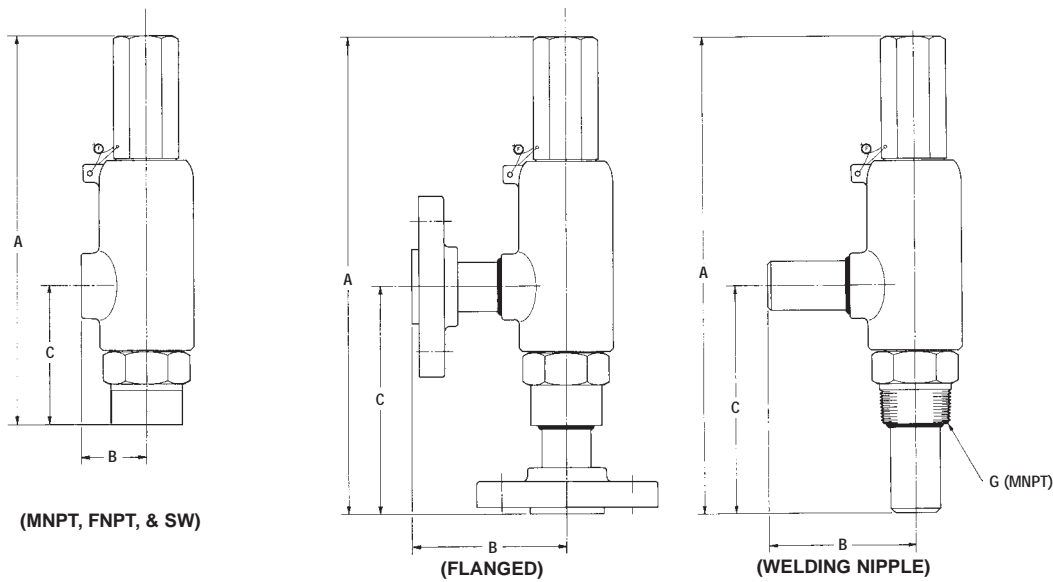

FLANGED CONNECTIONS

Orifice Area Sq. In.	Valve Size Inlet x Outlet	ANSI Flange Class		US Customary Units (Inches)				Metric Units (millimeters)			Weight	
		Inlet RF	Outlet RF	A (Max.)	B	C	G ¹ (MNPT)	A (Max.)	B	C	Lbs.	Kgs.
0.068 & 0.125	1/2 x 1	150#	150#	14	5 3/16	6 1/4	1	356	132	159	15	6.8
		300#	150#									
	600#	150#										
	900#	300#										
	3/4 x 1	1500#	300#	16 1/8	5 15/16	6 1/4	1	410	151	159	22	9.9
		2500#	300#	13 15/16	5 3/16	6 3/16	1 1/4	354	132	157	15	6.8
150#		150#										
300#		150#										
600#	150#											
1 x 1	900#	300#	16 1/8	5 15/16	6 1/4	1 1/4	410	151	159	22	9.9	
	1500#	300#	14 7/8	5 3/16	7 1/8	1 1/2	378	132	181	15	6.8	
	2500#	300#										
	150#	150#										
300#	150#											
0.223	1 x 1 1/2	600#	150#	16 13/16	5 13/16	6 15/16	1 1/2	427	148	176	26	11.7
		900#	300#									
		150#	150#									
		300#	150#									
0.350	1 1/2 x 2	600#	150#	17 7/8	8 3/16	7 3/16	2	454	208	183	30	13.6
		150#	150#									
		300#	150#									
0.573	1 1/2 x 2 1/2	600#	150#	17 1/8	8 3/16	7 7/16	2	435	208	189	32	14.5
		150#	150#									
		300#	150#									

General Note:

1. Same pipe thread connections also used on socket weld models with corresponding inlet sizes.
2. Tolerance for "B" and "C" dimensions is $\pm 1/8"$.

Process Pressure Relief Valves



SERIES 2600/2600L

- ASME NB Certified: Air, Steam & Water
- Sizes: 1" x 2" to 20" x 24"
- Pressure Range: 15 psig to 6000 psig
- Temperature Range: -450°F to +1500°F
- Materials: Carbon Steel, Stainless, Monel & Hastelloy C
- Options: Balanced Bellows, O-Ring Seat, Open Bonnet

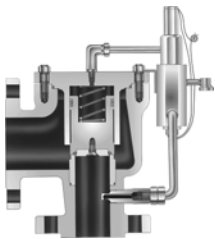

SERIES 3800 Pilot Operated

- ASME NB Certified: Air, Steam & Water
- Sizes: 1" x 2" to 12" x 16"
- Pressure Range: 15 psig to 6170 psig
- Temperature Range: -450°F to +500°F
- Materials: Steel Body & Bonnet, Stainless Steel Trim
- Options: Modulating Pilot Control, Complete 316 Stainless Steel Construction

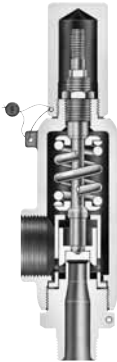

SERIES 2700

- ASME NB Certified: Air, Steam & Water
- Sizes: 1/2" x 1" to 1-1/2" x 2-1/2"
- Pressure Range: 15 psig to 6500 psig
- Temperature Range: -450°F to +750°F
- Materials: Stainless Steel Body & Trim, Carbon Steel Bonnet
- Options: Stainless Steel, Monel & Hastelloy Materials, O-Ring Seats, Flanged, Socket Weld, Welding Nipple, & Sanitary Connections

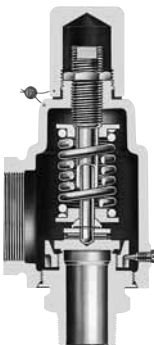

SERIES 2850/2856

- ASME NB Certified: Air & Steam
- Sizes: 3/4" x 1" to 1-1/2" x 2" (2850)
3/4" x 1-1/4" to 2" x 3" (2856)
- Pressure Range: 15 psig to 300 psig
- Temperature Range:
-20° F to +750°F (2850)
-450° F to +400°F (2856)
- Materials: Stainless Steel Body & Trim
Steel Bonnet (2850)
Brass Body & Trim, Bronze Bonnet (2856)

Steam Safety Valves

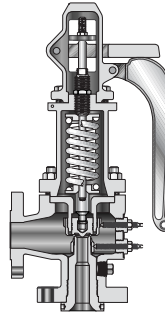

SERIES 4200

- ASME NB Section I & VIII Certified: Steam & Air
- Sizes 1 1/4" x 1 1/2" to 6" x 8"
- Pressure Range: 15 psig to 1000 psig
- Temperature Range: -20°F to +1000°F
- Materials: Carbon / Alloy St. & Stainless Steel.

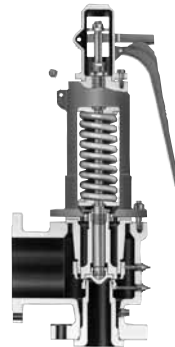

SERIES 6400/6600

- ASME NB Section I & VIII Certified: Steam & Air
- Sizes: 1" x 2" to 4" x 6"
- Pressure Range: 15 psig to 1500 psig
- Temperature Range: -20°F to +1000°F
- Materials: Carbon and Stainless Steel
- Options: Exposed Spring & Closed Bonnet

Special Purpose Pressure Relief Valves

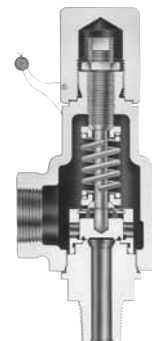

SERIES 1890/1896M

- ASME NB Certified: Air, Steam & Water
- Sizes: 1/2" x 1" & 3/4" x 1" (1890)
1/2" x 3/4" & 3/4" x 3/4" (1896M)
- Pressure Range:
15 psig to 800 psig (1890)
15 psig to 300 psig (1896M)
- Temperature Range:
-20°F to +750°F (1890)
-450°F to +400°F (1896M)
- Materials:
Stainless Steel Body & Trim (1890)
Brass Body & Trim, Bronze Bonnet (1896M)

Test Stands



MODELS T1500 & T6000

- Air & Water Testing
- Maximum Pressures of 1500 psig and 6000 psig
- Test Valves to 8" Inlet Size
- Stainless Steel Test Drum & Test Table
- Digital Test Gauge



Farris Engineering Products & Services



Process Pressure Relief Valves

Series 2600	ASME NB Certified for Air, Steam and Water
Series 3800	ASME NB Certified for Air, Steam and Water
Series 2700	ASME NB Certified for Air, Steam and Water
Series 1890/1896M	ASME NB Certified for Air, Steam and Water
Series 2850/2856	ASME NB Certified for Air and Steam

Steam Safety Valves

Series 4200	ASME NB Certified for Steam – Section I & VIII
Series 6400/6600	ASME NB Certified for Steam – Section I & VIII

Universal Test Stand

Tests Valves on Air and Water

SizeMaster™ Mark IV

Pressure Relief Valve Engineering Software
for Sizing and Selection

FAST Centers (Farris Authorized Service Team)

“Understanding what the Customer wants...making it happen!”

- Worldwide Network of Service Centers with Factory Trained Technicians
- Local Inventory with 24 hour a day / 7 day a week support
- Access to Worldwide Farris Inventory through the Web
- ASME/National Board approved Assembly & Test Facilities
- Application and Sizing & Selection Support

The following is a list of Farris approvals currently on record:

- ASME “V”, “UV” and “NV” approvals
- National Board “NB” approval
- ISO 9001-2000
- US Coast Guard approval
- PED 97/23/EC (European Pressure Equipment Directive)
- ATEX 94/9/EC (European Potentially Explosive Atmospheres)
- Canadian TSSA Registration
- China Safety Quality License
- Russian GOSH-R and GGNT (Russian Certification and Permits)
- First Point Assessment Limited



Farris Engineering

Division of Curtiss-Wright Flow Control Corporation

10195 Brecksville Road, Brecksville, OH 44141 USA • Telephone: 440-838-7690 • Fax: 440-838-7699 • www.cwfc.com

Facilities: Brecksville, OH USA, E. Farmingdale, NY USA, Brantford, Ontario Canada, Bridport, UK.

Offices: worldwide. For a listing of our global sales network, visit our website at www.cwfc.com.

While this information is presented in good faith and believed to be accurate, Farris Engineering does not guarantee satisfactory results from reliance upon such information. Nothing contained herein is to be construed as a warranty or guarantee, expressed or implied, regarding the performance, merchantability, fitness or any other matter with respect to the products, nor as a recommendation to use any product or process in conflict with any patent. Farris Engineering reserves the right, without notice, to alter or improve the designs or specifications of the products described herein.